



PRM-x.3

Analog I/O extension module

User guide

Contents

Introduction	2
1. Overview	3
1.1 Intended use	3
1.2 Ordering code	3
1.3 Front indicators	4
2. Specifications	5
2.1 Environmental conditions	7
2.2 Galvanic isolation	7
3. Installation	8
3.1 Internal bus	8
3.2 Wiring	9
3.2.1 Resistance thermometer	10
3.2.2 Thermocouple	10
3.2.3 I/U sensors	10
3.2.4 Resistance sensor	11
3.2.5 Output wiring	11
4. Configuration	12
5. Firmware update	14
6. Calibration	15
6.1 Input calibration	15
6.2 Output calibration	16
7. Maintenance	18
8. Transportation and storage	19
9. Scope of delivery	20
Appendix A Dimensions	21

Introduction

Introduction

Terms and abbreviations

ALP – programming software akYtec ALP for programming PR series relays, based on Function Block Diagram (FBD) programming language

Application – user program created using ALP software

ADC – analog-digital converter

DAC – digital-analog converter

Symbols and keywords

DANGER

DANGER indicates an **imminent dangerous situation** that will result in death or serious injuries if not prevented.

WARNING

WARNING indicates a **potentially dangerous situation** that could result in death or serious injuries.

CAUTION

CAUTION indicates a **potentially dangerous situation** that could result in minor injuries.

NOTICE

NOTICE indicates a **potentially dangerous situation** that could result in damage to property.

NOTE

NOTE indicates helpful tips and recommendations, as well as information for efficient and trouble-free operation.

Overview

1. Overview

PRM extension module provides additional inputs and outputs for the basic device PR200. The module inputs and outputs are controlled by a program running on PR200. To enable control, the module should be added to the PR200 configuration in ALP (sect. 4).

The module is a passive device and cannot be used without connection with the basic device over internal bus.

All modifications are designed in a plastic enclosure for DIN rail mounting.

Each PRM module is powered independently of the basic device. The basic device and the modules can be operated with different supply voltages.

1.1 Intended use

Extension modules of PRM series have been designed and built solely for the intended use described in this manual, and may only be used accordingly. The technical specifications contained in this manual must be observed.

The module may be operated only in properly installed condition.

Improper use

Any other use is considered improper. Especially to note:

- This device should not be used for medical devices which receive, control or otherwise affect human life or physical health.
- The device should not be used in an explosive environment.
- The device should not be used in an atmosphere with chemically active substance.

1.2 Ordering code

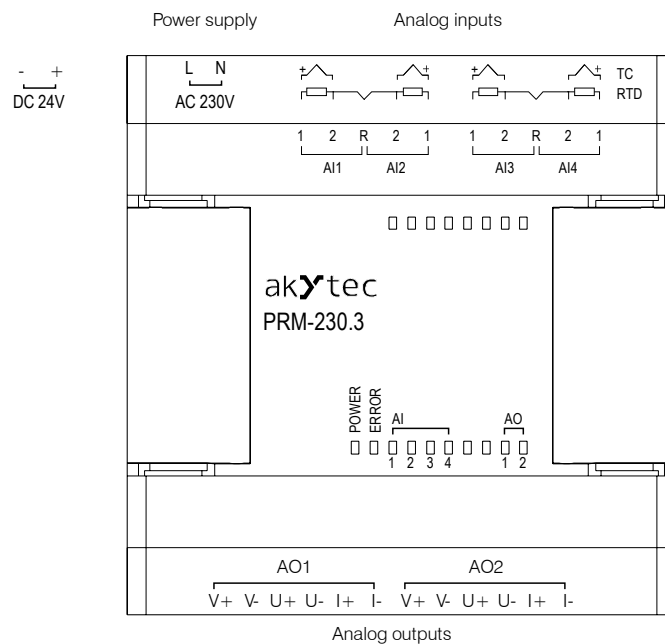
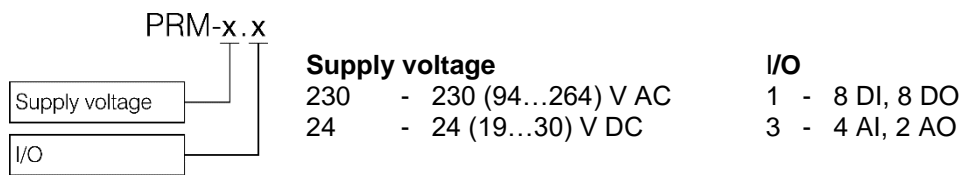

Fig. 1.1 Front view

Overview

1.3 Front indicators

Table 1.1 LED indicators

Indicator	Color	State	Description
POWER	Green	ON	Power on
ERROR	Red	Flashing	No communication with the basic device
			Device model does not match the model specified in the project
			The firmware version of the basic device and the module are incompatible
AI	Yellow	ON	Parameter Sensor type selected and sensor connected
		OFF	Parameter Sensor type set to OFF. The current input value in the program is replaced with the value 55555 .
		Flashing	Sensor fault (Table 1.2)
AO	Yellow	ON	Parameter Output signal type selected
		OFF	Parameter Output signal type set to OFF
		Flashing	Output fault: <ul style="list-style-type: none"> – No output voltage supply – DAC high temperature – Load break in current mode

Table 1.2 Analog input fault codes

Code	Description
33333	Short circuit
44444	Sensor break
66666	Input value is outside the ADC valid range
77777	Input value is outside the sensor valid range
88888	Cold junction sensor fault

Specifications

2. Specifications

Table 2.1 General specification

Device	PRM-230.3	PRM-24.3
Power supply	230 (90...264) V AC 50 (47...63) Hz	24 (19 ... 30) V DC
Power consumption, max.	8 VA	4 W
Galvanic isolation (sect. 2.2)	2830 V	1780 V
Inputs	Digital	—
	Analog	4
Outputs	Digital	—
	Analog	2
IP Code	IP20	
Operation temperature	-20...+55 °C	
Dimensions	88 x 90 x 58 mm	
Mounting	DIN rail (35 mm)	
Weight	approx. 250 g	

Table 2.2 Analog inputs

Input signal	see Table 2.4	
ADC resolution	16 bit	
Accuracy	RTD	0.25 %
	TC	0.5 %
	I / U signals	0.25 %
Sampling time per input, max.	RTD	0.8 s
	TC	0.6 s
	I / U signals	0.6 s
Input resistance, min.	10 kΩ	
Shunt resistor	45...50 Ω	
Galvanic isolation between inputs (sect. 2.2)	—	

Table 2.3 Analog outputs

Output types	0-24 mA 0-20 mA 4-20 mA 0-5 V 0-10 V	
DAC resolution	12 bit	
Accuracy	± 0.5 %	
Temperature influence	± 0.25 %	
Galvanic isolation between outputs (sect. 2.2)	2830 V	
Voltage supply (external, each output separately)	15...30 V DC	
Output load, max.	0-5 mA, 0-20 mA, 4-20 mA	1000 Ω
	0-5 V, 0-10 V	300 Ω

Specifications

Table 2.4 Sensors / input signals

Sensor / Input signal	Measurement range	Accuracy
Resistive signals		
0 ... 3950 Ω	0...100%	± 0.25
Standard I / U signals		
0-1 V	0...100 %	± 0.25 %
-50...50 mV	0...100 %	
0-5 mA	0...100 %	
0-20 mA	0...100 %	
4-20 mA	0...100 %	
RTD according to IEC 60751:2008		
Pt50 ($\alpha=0.00385$ $^{\circ}\text{C}^{-1}$)	-200...+850 $^{\circ}\text{C}$	± 0.25 %
Pt100 ($\alpha=0.00385$ $^{\circ}\text{C}^{-1}$)	-200...+850 $^{\circ}\text{C}$	
Pt500 ($\alpha=0.00385$ $^{\circ}\text{C}^{-1}$)	-200...+850 $^{\circ}\text{C}$	
Pt1000 ($\alpha=0.00385$ $^{\circ}\text{C}^{-1}$)	-200...+850 $^{\circ}\text{C}$	
RTD according to GOST 6651-2009 and 6551-94		
50P ($\alpha=0.00391$ $^{\circ}\text{C}^{-1}$)	-240...+1100 $^{\circ}\text{C}$	± 0.25 %
50M ($\alpha=0.00428$ $^{\circ}\text{C}^{-1}$)	-200...+200 $^{\circ}\text{C}$	
Cu50 ($\alpha=0.00426$ $^{\circ}\text{C}^{-1}$)	-50...+200 $^{\circ}\text{C}$	
100P ($\alpha=0.00391$ $^{\circ}\text{C}^{-1}$)	-240...+1100 $^{\circ}\text{C}$	
100M ($\alpha=0.00428$ $^{\circ}\text{C}^{-1}$)	-200...+200 $^{\circ}\text{C}$	
Cu100 ($\alpha=0.00426$ $^{\circ}\text{C}^{-1}$)	-50...+200 $^{\circ}\text{C}$	
Ni100 ($\alpha=0.00617$ $^{\circ}\text{C}^{-1}$)	-60...+180 $^{\circ}\text{C}$	
500P ($\alpha=0.00391$ $^{\circ}\text{C}^{-1}$)	-240...+1100 $^{\circ}\text{C}$	
500M ($\alpha=0.00428$ $^{\circ}\text{C}^{-1}$)	-200...+200 $^{\circ}\text{C}$	
Cu500 ($\alpha=0.00426$ $^{\circ}\text{C}^{-1}$)	-50...+200 $^{\circ}\text{C}$	
Ni500 ($\alpha=0.00617$ $^{\circ}\text{C}^{-1}$)	-60...+180 $^{\circ}\text{C}$	
1000P ($\alpha=0.00391$ $^{\circ}\text{C}^{-1}$)	-240...+1100 $^{\circ}\text{C}$	
1000M ($\alpha=0.00428$ $^{\circ}\text{C}^{-1}$)	-200...+200 $^{\circ}\text{C}$	
Cu1000 ($\alpha=0.00426$ $^{\circ}\text{C}^{-1}$)	-50...+200 $^{\circ}\text{C}$	
Ni1000 ($\alpha=0.00617$ $^{\circ}\text{C}^{-1}$)	-60...+180 $^{\circ}\text{C}$	
TC according to IEC 60584-1:20131		
J	-200...+1200 $^{\circ}\text{C}$	± 0.5 %
N	-200...+1300 $^{\circ}\text{C}$	
K	-200...+1360 $^{\circ}\text{C}$	
S	-50...+1750 $^{\circ}\text{C}$	
R	-50...+1750 $^{\circ}\text{C}$	
T	-250...+ 400 $^{\circ}\text{C}$	
B	+200...+1800 $^{\circ}\text{C}$	
A-1	0...+ 2500 $^{\circ}\text{C}$	
TC according to GOST 8.585		
L	-200...+800 $^{\circ}\text{C}$	± 0.5 %
A-2	0...+1800 $^{\circ}\text{C}$	
A-3	0...+1800 $^{\circ}\text{C}$	

Specifications

2.1 Environmental conditions

The device is designed for natural convection cooling. It should be taken into account when choosing the installation site.

The following environment conditions must be observed:

- dry and controlled environment with low dust level
- closed non-hazardous areas, free of corrosive or flammable gases

Table 2.5

Conditions	Permissible range
Ambient operating temperature	-20...+55°C
Storage temperature	-25...+55°C
Relative humidity	up to 80% (at +25°C, non-condensing)
Altitude	up to 2000 m above sea level
EMC immunity	conforms to IEC 61000-6-2
EMC emission	conforms to IEC 61000-6-4

2.2 Galvanic isolation

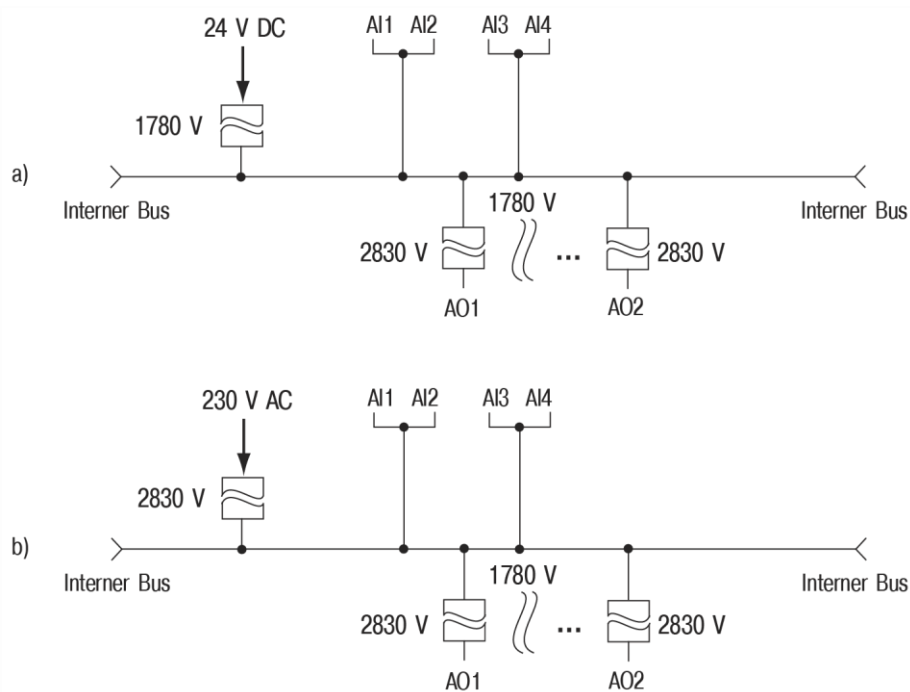

Fig. 2.1 Galvanic isolation PRM-24 (a) and PRM-230 (b)

Installation

3. Installation

DANGER

Electric shock could kill or seriously injure.



All electrical connections must be performed by a fully qualified electrician.

Ensure that the mains voltage matches the voltage marked on the nameplate.

Ensure that the device is provided with its own power supply line and electric fuse.

WARNING

The device must be powered off before connecting to internal bus or peripheral devices.



Switch on the power supply only after the wiring of the device has been completed.

Remove the terminal blocks only after powering off the device and all connected equipment.

Do not feed any external devices from the power contacts of the device.

NOTICE



Supply voltage for 24 VDC models may not exceed 30 V. Higher voltage can damage the device.

If the supply voltage is lower than 19 VDC, the device cannot operate properly but will not be damaged.

NOTICE



Signal cables should be routed separately or screened from the supply cables.

Shielded cable should be used for the signal lines to ensure the EMC precautions.

NOTE



Before powering on, make sure that the device was stored at the specified ambient temperature (-20 ... +55 °C) for at least 30 minutes.

The extension modules of PRM series are mounted on DIN rail to the left of the PR200 basic device.

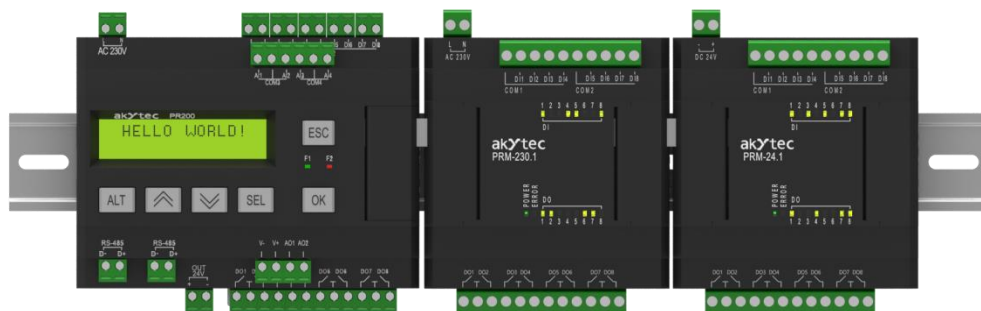

Fig. 3.1

After mounting on the DIN rail, an internal bus connection between PR200 and the modules should be implemented (sect. 3.1). Then the power supply and the peripheral devices should be connected to the module terminal blocks (sect. 3.2).

For dimension drawing see Appendix A.

3.1 Internal bus

An internal high-speed bus provides the same high-speed performance of the module that of the basic device. It allows reading of the input values and writing of the output values of the module within one program cycle.

Installation

The PRM modules are connected to PR200 in series. Maximum two modules can be connected. To implement the internal bus, connect PRM to PR200, using the supplied 4.5 cm flat cable.

PRM has two **EXT** connectors located under the right and left covers on the device front. The connector under the left cover is used to connect the 1st PRM to PR200 or the 2nd PRM to the 1st one. The connector under the right cover is used to connect PR200 to the 1st PRM or the 1st PRM to the 2nd one.

When connected, the flat cable should be placed in a special recess under the cover to enable PRM to be pushed close to PR200 (Fig. 3.2).

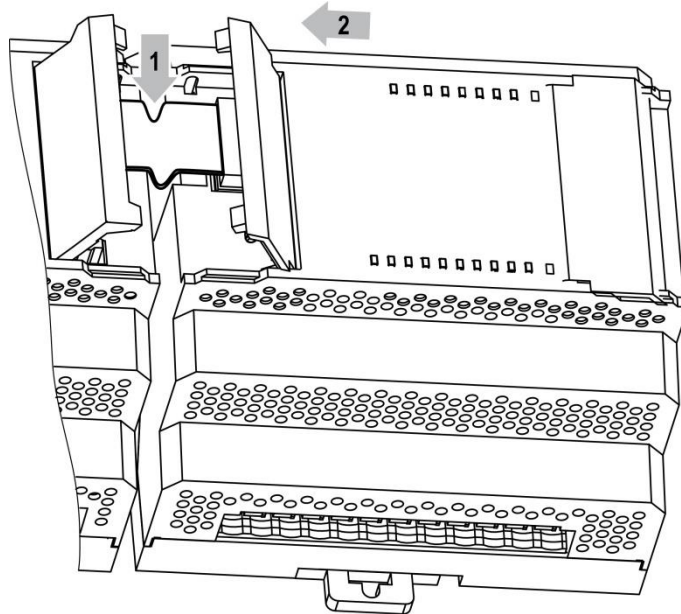

Fig. 3.2

3.2 Wiring

For terminal block layout see Fig. 3.3, 3.4.

For terminal assignment see Tab. 3.1.

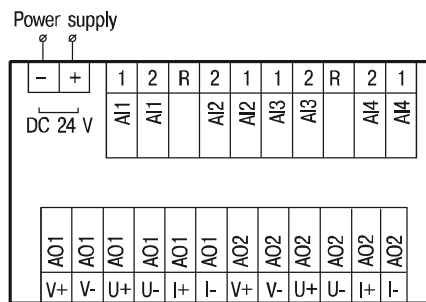

Fig. 3.3 PRM-24.3 terminal block layout

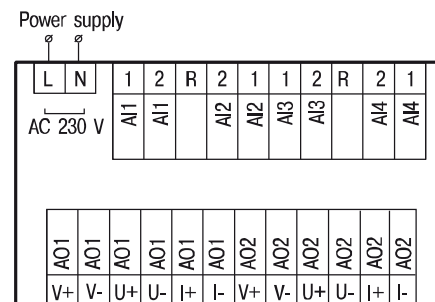

Fig. 3.4 PRM-230.3 terminal block layout

Table 3.1 Terminal assignment

Marking	Description	Marking	Description
DC 24 V / - or AC 230 V	Power supply	AO1 / V+	24 VDC supply AO1+
DC 24 V / + or AC 230 V	Power supply	AO1 / V-	24 VDC supply AO1-
AI1 / 1	AI1 terminal 1	AO1 / U+	Voltage output AO1+
AI1 / 2	AI1 terminal 2	AO1 / U-	Voltage output AO1-
R	AI1 / AI2 common terminal	AO1 / I+	Current output AO1+
AI2 / 2	AI2 terminal 2	AO1 / I-	Current output AO1-

Installation

Marking	Description	Marking	Description
AI2 / 1	AI2 terminal 1	AO2 / V+	24 VDC supply AO2+
AI3 / 1	AI3 terminal 1	AO2 / V--	24 VDC supply AO2-
AI3 / 2	AI3 terminal 2	AO2 / U+	Voltage output AO1+
R	AI3 / AI4 common terminal	AO2 / U-	Voltage output AO1-
AI4 / 2	AI4 terminal 2	AO2 / I+	Current output AO1+
AI4 / 1	AI4 terminal 1	AO2 / I-	Current output AO1-

3.2.1 Resistance thermometer

2- or 3-wire sensors can be connected.

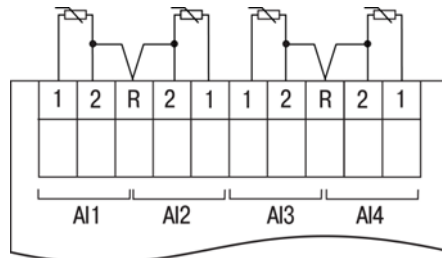
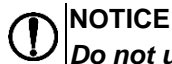

Fig. 3.5 RTD wiring

3.2.2 Thermocouple



Do not use a TC with not insulated hot junction. It can damage the module.

Cold junction compensation is provided for using with thermocouples. The built-in cold junction temperature sensor is placed next to the terminal block.

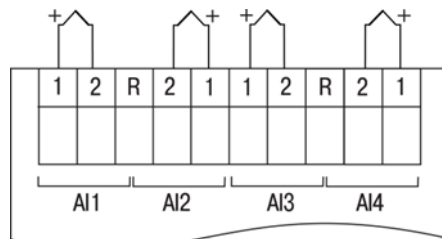

Fig. 3.6 TC wiring

3.2.3 I/U sensors

Voltage signal can be connected directly to the input terminals.

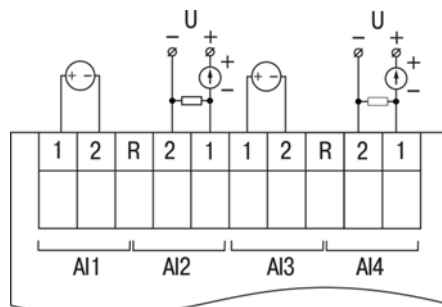

Fig. 3.7 I/U sensor wiring

To measure a current signal, a shunt resistor of $50\ \Omega$ ($\pm 1\%$) has to be connected in parallel (see Fig. 4.8). It is recommended to use resistors included in the package or other high-stable resistors.

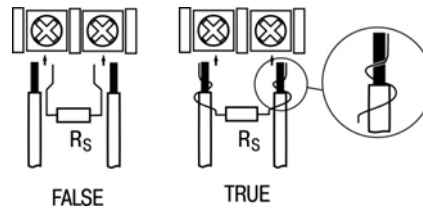

Fig. 3.8 Shunt resistor connection

You can use a resistor 45...50 Ω, whose value should be noted in the parameter **Shunt resistor** in the properties of the input in ALP. It is recommended to calibrate the input with the shunt (sect. 5).

NOTICE
 *It is necessary to provide safe contact between signal and resistor wires. Otherwise the input can be damaged.*

3.2.4 Resistance sensor

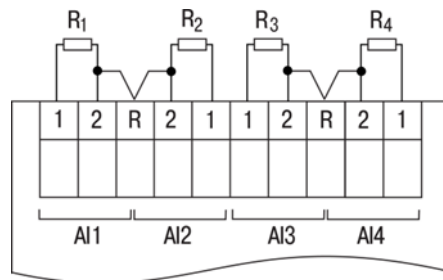

Fig. 3.9 Resistance sensor wiring

3.2.5 Output wiring

The analog outputs are galvanically isolated. Each output can be powered separately if necessary. The negative contacts V-, U- and I- of different outputs are interconnected inside the device.

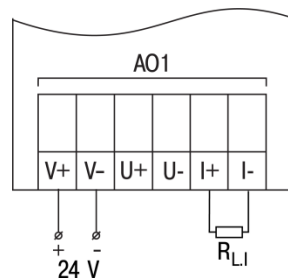

Fig. 3.10 Current output wiring

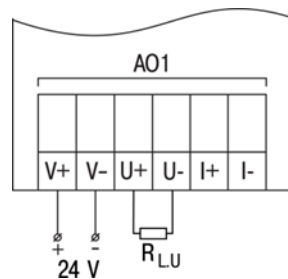

Fig. 3.11 Voltage output wiring

Configuration

4. Configuration

To add a module to the basic device configuration:

- open a PR200 project in ALP
- open **Device configuration**
- select the item **Extension modules** in the structure tree
- add PRM module using the context menu (Fig. 4.1)

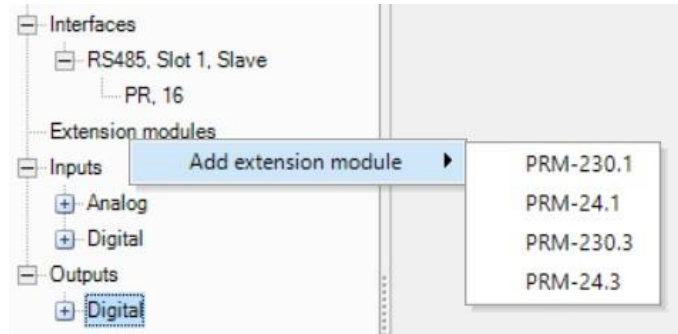

Fig. 4.1

The parameter **Extension number** (Fig. 4.2) is the position of PRM, when counting from left to right from PR200. The next module to the left of PR200 should be added to the configuration first to be assigned as No.1. The next added module is always assigned as No.2. If there is no module assigned as No.1, a new module cannot be assigned as No.2.

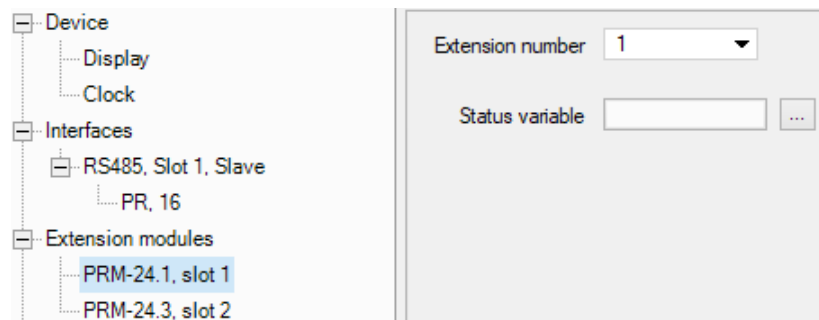

Fig. 4.2

Data exchange between PR200 and PRM No.2 is carried out through PRM No.1. If PRM No.1 is powered off, the data exchange between PR200 and PRM No.2 is interrupted.

PRM can be removed from the project only after disconnecting all the variables assigned to its inputs and outputs.

The position of PRM in the configuration can be changed using the context menu.

The project can be transferred to P200 irrespective of whether the modules are connected or not.

When a module is added to configuration, additional inputs AI1...AI4 and outputs AO1...AO2 with the extension number in brackets appear in the workspace (Fig.4.3).

When the module is added to the project, its inputs and outputs will be sampled.

To read the input values or change the status of the outputs, create variables of the appropriate type and associate them with module I/Os. If it is necessary to sample the module I/Os over the network, they have to be associated with network variables.

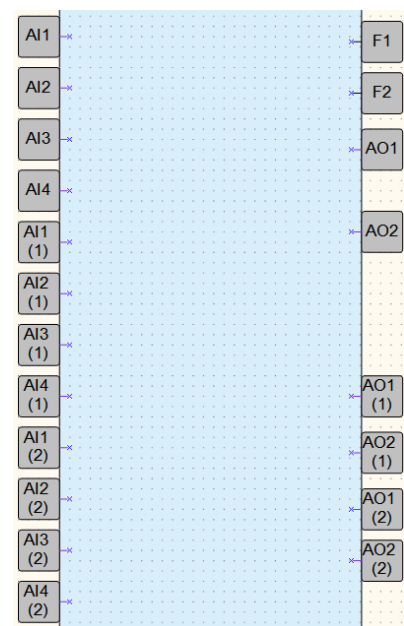

Fig. 4.3

Configuration

Table 4.1 Module parameters

Parameter	Description
Common	
Status	<p>Select a BOOL variable to read the status:</p> <ul style="list-style-type: none"> – TRUE, if the communication with PRM is established and the PRM model is the same as the specified in the configuration – FALSE, if the communication with PRM is lost or the PRM model differs from that specified in the configuration
Inputs	
Sensor type	<p>The type of sensor connected to the input. The input value will be converted into the unit corresponding to the sensor type (for example, with RTD or thermocouple, the input values will be converted into degrees Celsius).</p> <p>The default setting OFF means that the input is disabled and will not be sampled. The setting OFF for unused channels increases the sampling rate.</p>
Filter time constant	0...65 seconds, 0 – filter disabled
Shunt resistor	External shunt resistor 45...50 Ω
Lower measuring limit	Minimum level of sensor output signal
Upper measuring limit	Maximum level of sensor output signal
Outputs	
Safe state	Output signal in case of loss of communication with the basic device
Output signal type	The type of output signal determines the calibration coefficients used for signal conversion

Firmware update

5. Firmware update

If a new project is loaded into the device and the firmware of the device and extension module are incompatible, the connection between them will be interrupted and the red **ERROR** indicator on the module will flash.

To update firmware:

- Connect the module to the basic device over internal bus
- Connect the basic device to the PC
- Switch on the power supplies of the basic device and the module
- Start ALP and select the menu item **Device > Firmware update**
- Click **No** in the opened dialog to select the module manually
- Open the tab **Extension modules**, select the extension number and the device model and confirm with **Select**

 **NOTICE**
Ensure reliable power supply of the basic device and modules during the update. If it failed, the update should be probably repeated.

Calibration

6. Calibration

If the accuracy of the input or output of the module is no longer in accordance with the specification, it can be calibrated. The module must be connected to the basic device to be calibrated. The calibration is carried out the same way as with the basic device.

NOTICE
 **Ensure reliable power supply of the basic device and modules during the calibration. If it fails, the calibration should be repeated.**

- Each analog input and output has its own calibration coefficients for each sensor type.
- Calibration is performed using a reference signal source connected to the device input or output.
- The calibration coefficients are calculated based on the ratio between the current input signal and the reference signal and stored in the non-volatile device memory.
- If the calculated coefficients go beyond the permissible limits, a message about the error cause will be displayed.

6.1 Input calibration

Input signals: 4-20 mA, 0-10 V, 0-4000 ohm

1. To calibrate an input, connect the reference signal source to it (Fig. 6.1).

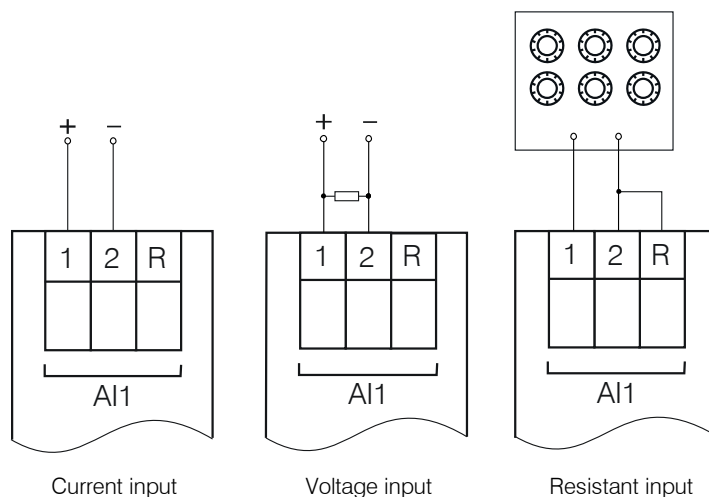

Fig. 6.1 Connection of the reference signal source to an input

2. Connect the module to the basic device over internal bus
3. Connect the basic device to the PC
4. Switch on the power supplies of the basic device and the module
5. Start ALP and select the menu item **Device > Calibration** to start the calibration tool
6. Select the appropriate PRM model in the dialog window
7. Select **Analog inputs** as calibration target
8. Select the type of input signal and other calibration parameters (Fig. 6.2)

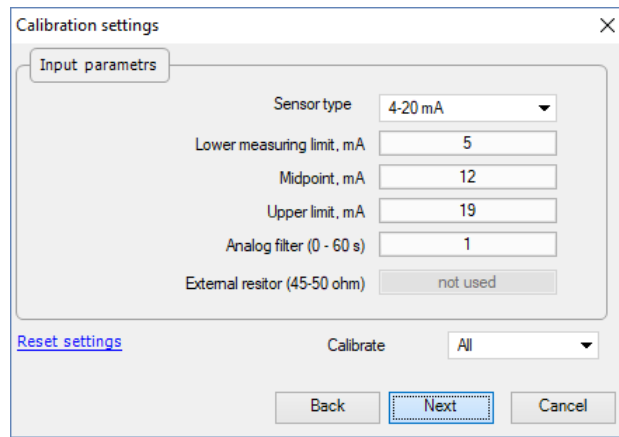

Fig. 6.2 Calibration settings

- Set the three points for calibration curve and the filter time constant. The greater the filter time constant, the longer the calibration process will take, but the more accurate calculation of the coefficients will be achieved.
- Select the input to calibrate. If you select **All**, all inputs will be calibrated sequentially, therefore the appropriate reference signal has to be applied to all inputs.

9. Click “Next” and follow the instructions.

Click the item **Reset settings** to use the default calibration settings.

6.2 Output calibration

To calibrate the output:

1. Connect the reference signal source according to Fig. 6.3 or 6.4 to the output.

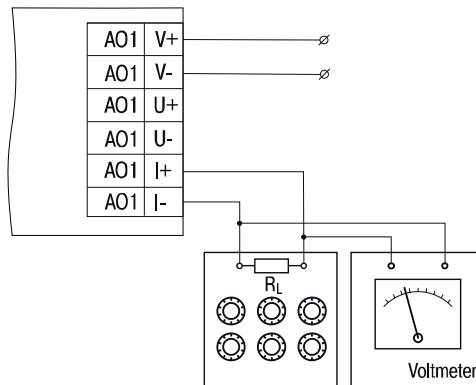

Fig. 6.3 Connection of the current reference signal source to an output ($R_L < 300 \Omega$)

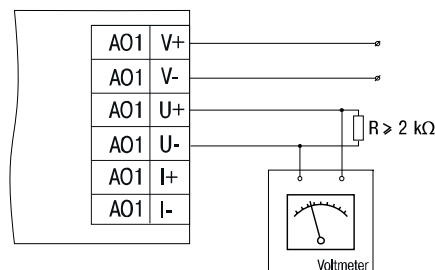

Fig. 6.4 Connection of the voltage reference signal source to an output

2. Connect the module to the basic device over internal bus.
3. Connect the basic device to the PC.

Calibration

4. Switch on the power supplies of the basic device and the module.
5. Start ALP and select the menu item **Device > Calibration** to start the calibration tool.
6. Select the appropriate PRM model in the dialog window.
7. Select **Analog outputs** as calibration target.
8. Select the type of output signal and the output to be calibrated. If you select **All**, all outputs will be calibrated sequentially, so the appropriate reference signal has to be applied to all outputs.
9. Measure the signal on the output indicated in the upper right window corner, enter the value in the input field.

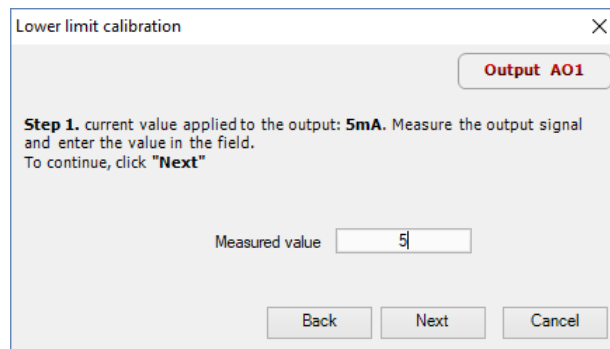

Fig. 6.5 Lower limit calibration

Click "Next" and follow the instructions.

Maintenance

7. Maintenance

The maintenance includes:

- cleaning of the housing and terminal blocks from dust, dirt and debris
- check the device fastening
- checking the wiring (connecting leads, fastenings, mechanical damage)

NOTICE



The device should be cleaned with a damp cloth only. No abrasives or solvent-containing cleaners may be used. During maintenance, observe the safety instructions in the section "Installation".

Transportation and storage

8. Transportation and storage

Pack the device in such a way as to protect it reliably against impact for storage and transportation. The original packaging provides optimum protection.

If the device is not taken immediately after delivery into operation, it must be carefully stored at a protected location. The device should not be stored in an atmosphere with chemically active substances.

Permitted storage temperature: -25...+55 °C

NOTE

The device may have been damaged during transportation.

Check the device for transport damage and completeness!

Report the transport damage immediately to the shipper and akYtec GmbH!

Scope of delivery

9. Scope of delivery

PRM	1
Short guide	1
Connecting cable	1
Shunt resistors	4
Terminal blocks (set)	1

**NOTE**

The manufacturer reserves the right to make changes to the scope of delivery.

Appendix A Dimensions

Appendix A Dimensions

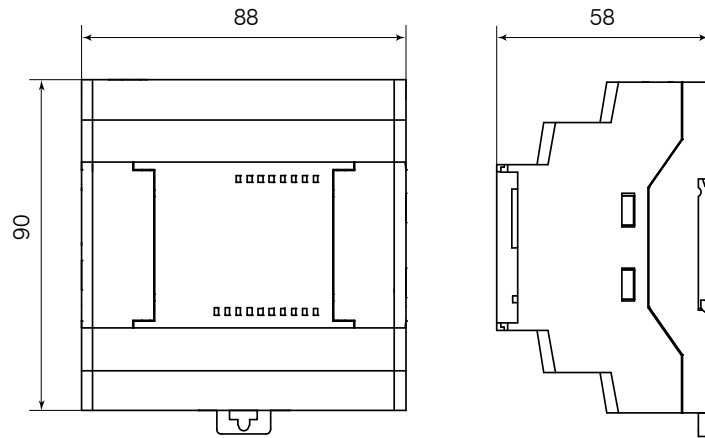

Fig A.1