

K-DRIVE PRODUCT CATALOG

KD700

BOOK STYLE SERIES

VECTOR VFD





KD700

Book type high-performance vector inverter

KD700 is the latest inverter that our company invested 2 million RMB in. Based on KD600, this product can meet all market demands at the cheapest price, supports TCP/IP (Modbus) protocol, individually paired PLC, PROFIBUS, PROFINET, CANOPEN, CAN, ETHERCAD, etc., and at the same time a parameter can automatically switch to photovoltaic water pump, elevator, synchronous machine, asynchronous machine, etc.



POWER RATINGS

1×220 - 240V	0.4 - 7.5kW
3×220 - 240V	0.4 - 220kW
3×380 - 480V	0.75 - 1000kW

COMPATIBILITY

Asynch motor control applicable
 Synch motor Control Application
 Off Grid Solar Pump
 Elevator Application

CONTROL TECHNOLOGY

VF / SVC1 / SVC2 / FVC
 SVC / VVC / FVC

FEATURES

Reliable

Ambient temperature 45° C without derating
 Thickened conformal coating
 Optimized cooling system

Less need for cooling or oversizing
 Resistant to harsh surroundings
 Lower temperature rise

User-friendly

Parameter copy
 Detachable control panel
 One platform numerous versions

Save time for Commissioning
 Easy for remote control
 Save stocks

Intelligent

Warning systems
 Multiple frequency references
 All-sided protection
 Online autotuning
 PC-based monitoring software
 Extensible features/parameter blocks

Warning before stop
 Powerful in intelligent applications
 Long lifetime & less maintance cost
 Intelligent response to delicate variation
 Easy to operate
 Make the drives "just for you"

STRUCTURAL HARDWARE FEATURES

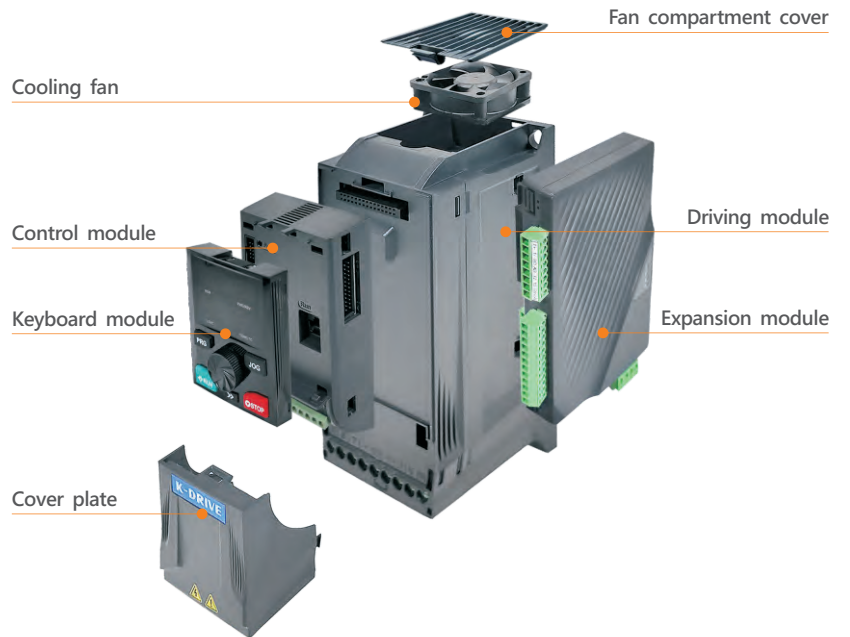
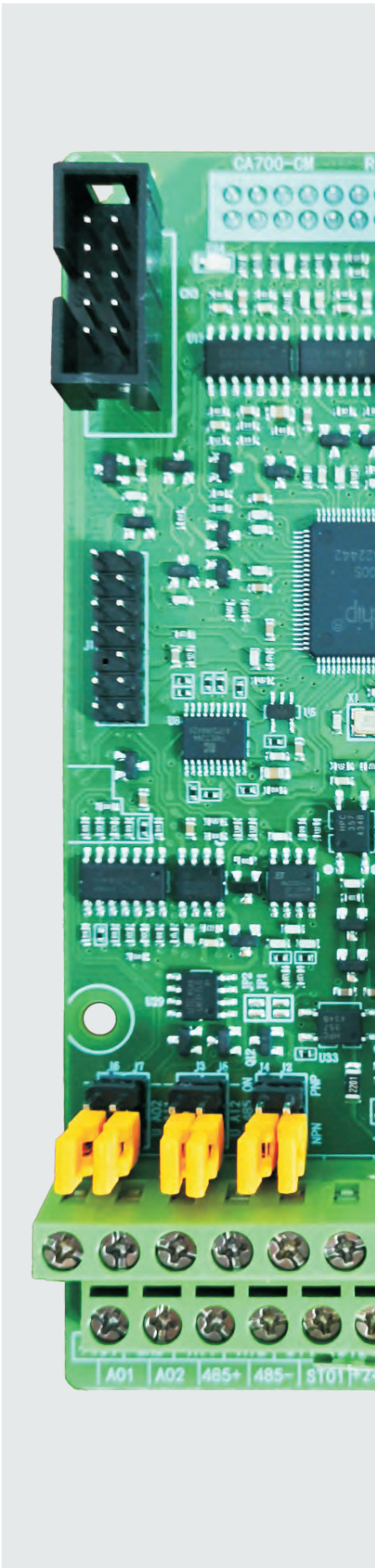

MODULARIZATION

Modular expansion house, supporting multiple forms of expansion simultaneously.

Increase business, flexibility, and control inventory



Reliable overcurrent ground protection

Output: Adopting three-phase current sampling and comprehensive overcurrent to ground short circuit protection;

Input: Equipped with buffer resistor charging circuit abnormal protection, the entire series is equipped with input phase loss hardware protection.

≤37G comes standard with a built-in brake unit, while 45G~160G can be optionally equipped with a built-in brake unit

>37G~110G can be optionally equipped with DC reactors, ≥132G comes standard with built-in DC reactance.



SUPPORTS LED AND LCD DISPLAY KEYPAD.

Both keypads support user-defined parameter copying between multiple machines by default. Parameter files can be copied to the PC and sent remotely to other debugging sites, which is convenient for remote management and remote debugging. (Can choose different language directly in the LCD keypad, such as Chinese, English, Polish, And Spain etc)



LED keyboard



LCD keyboard



The keyboard supports 300 meter remote Ethernet connection.



MAX 300m



PERFORMANCE CHARACTERISTICS

Multi speed operation

Supporting 16 speed operation, it can achieve simple PLC cycle operation to meet flexible customer process requirements;

PID control, sleep wake function

There are various sources of input and feedback, with output compensation and sleep wake-up function, which is convenient for applications such as constant pressure water supply;

Switching between two sets of motor parameters

Support parameter switching between two sets of motors, which can be modified or switched using DI terminals to adapt to both sets of motors.



Excellent and complete brake logic

Cooperating with the application of brake type motors in construction elevators, mine hoists, civilian elevators, etc., can achieve safe, stable, and comfortable control of the operation process;

Fire control mode

Can meet the relevant control requirements of users in fire protection mode;

STO safety torque shutdown control protection

Through the coordination of software and hardware, the safe shutdown of output torque is achieved, providing timely protection.



Tension control

Functions such as roll diameter calculation, thickness accumulation calculation, linear velocity calculation, tension compensation, tension taper, automatic detection of material breakage, and automatic roll change.

Stable and reliable

Independent air duct; Three proof UV coating; Preferred components and large margin selection.



Water pump



Woodworking machinery



Printing and packaging



Ceramic machinery



Industrial and mining



Fan



Textile printing and dyeing



Metalworking



Injection molding



CNC

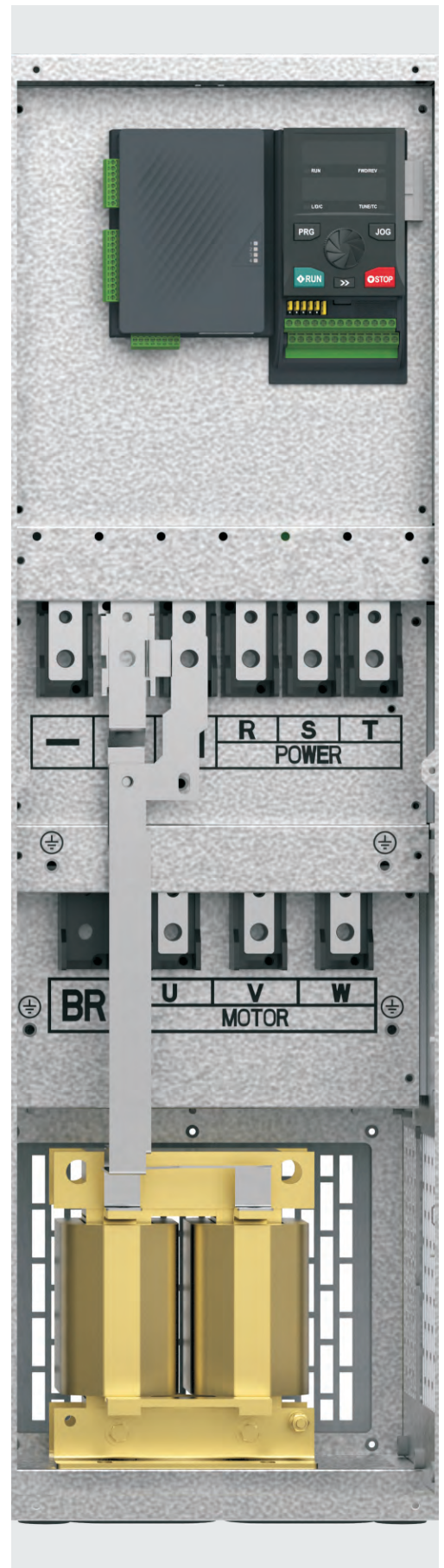

More Beyond inheritance

01

Rich Terminal Functions

Normal Controls board=other Brand VFD+IO Card, In order to improve our VFD convenience,all series vfd build in 7×DI (one for HDI) Input, 2×AI Input, 2×AO Output, 2×Relays Output and NPN&PNP, and Sto terminal,which can almost match more than 95% requirement in the market.



NOTE: Only 0.4kW-400kW are listed here. Please contact K-DRIVE for more information of other power ratings.

Latest dedicated chip



02

One Parameter to choose different Software

KD700 used with very big capacity IGBT, which can use one parameter to change different software as customer need including ASYNCHRONOURS and SYNCHRONOUS, off grid solar pump, and elevactor etc.

03

Hot pluggable and detachable control panel

Quite conveninet for users to implement remote control via a cable connection, and the settings are easily transferred via the control pannel to another drive or from a PC to a drive with K-DRIVE Drive Monitoring Software

04

Abundant hot-plugged options

One platform millions of version is the basic design concept of KD700. Numerous options are available and can be mounted and tested at factory or be hot-plugged in later for change-over or upgrade.



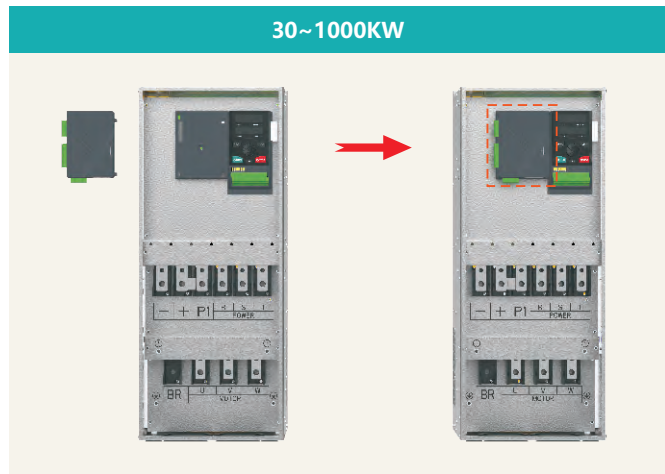
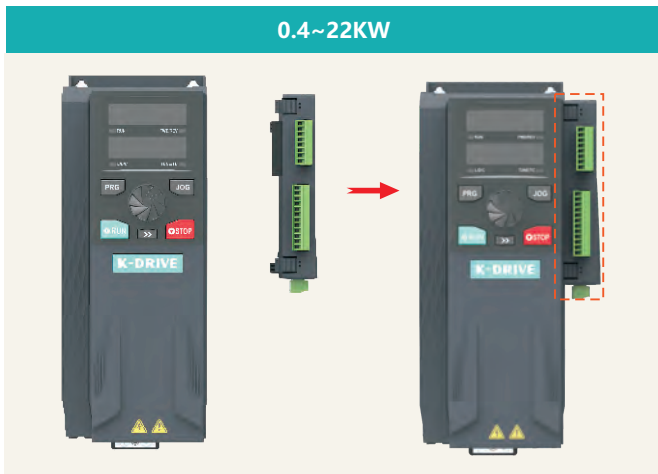

Outer Cards Install way: One model support 3 cards combination freely.
Such as : 2 IO+ 1PG Or 1PG+ 2 communication cards.

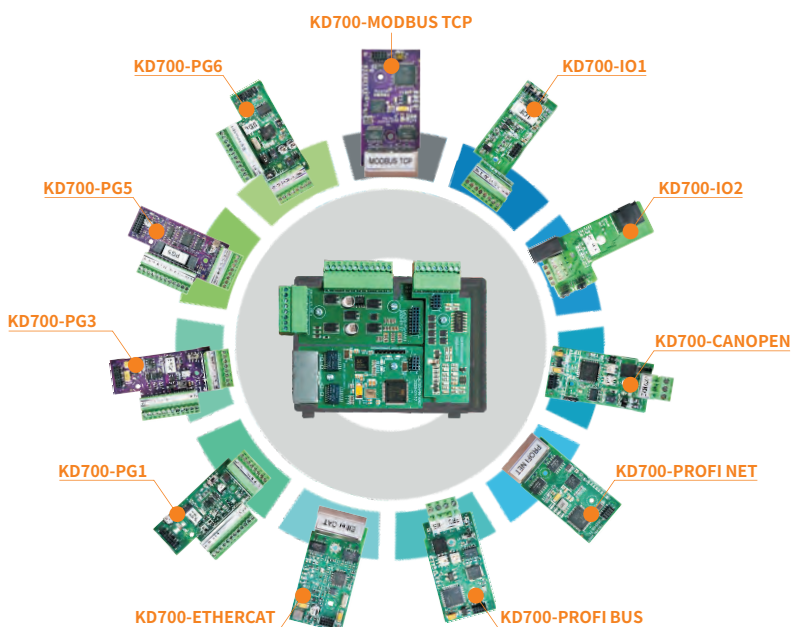

Modbus TCP

PROFI[®]
BUS

PROFI[®]
NET

EtherCAT[®]

CANopen

EtherNet/IP[™]

05

Four control modes

KD700 drives are equipped with four kinds of control modes, V/Hz, SVC1, SVC2, VC, fulfilling a wide variety of demanding industrial applications.

Control mode	V/Hz	SVC1	SVC2	VC
Speed adjustable range	1:100	1:100	1:200	1:1000
Speed accuracy	±0.5%	±0.2%	±0.2%	±0.02%
Speed ripple	/	±0.3%	±0.3%	±0.1%

06

Supreme start torque

The drives of KD700 series can output 200% of the rated output torque at 0Hz under VC control mode.

200%

07

Torque control programmable

Speed control and torque control are programmable via parameter or can be switched via terminal digital input at KD700. Torque control accuracy reaches $\pm 5\%$, while response time is less than 5ms.



08

Four kinds of position control

Under VC control mode, a KD700 drive can undertake the task of zero-speed clamping, angular positioning*1, fixed-length control*2, and positioning via pulse input. The precision of positioning at pulse input reaches ± 1 pulse.

NOTE: *1: 4 angular positions realizable, *2: 8 fixed-length positions programmable.



09

Flexible electronic gear

Through the function of electronic gear at KD700, closed-loop vector control still can be performed even the encoder is not mounted at the motor shaft, quite convenient for applications when the encoder is not easily to be mounted at the motor shaft.

NOTE: *3: The shaft that the encoder is mounted at should have fixed speed ratio with motor shaft.

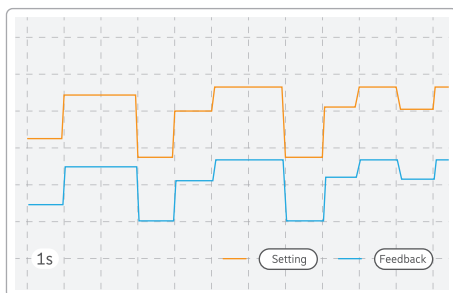

10

Quick dynamic response

Torque response time of KD700 drives is as short as 10ms at SVC1 or SVC2 mode.

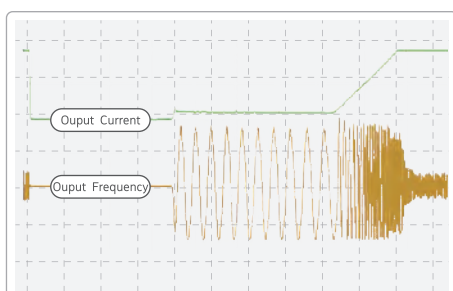

11

Cycle-By-Cycle current limit

The KD700 drives are equipped with the function of cycle-by-cycle current limit. The drive knows how to adjust its output frequency and current suitably to avoid trip when there is a saltation at the load.

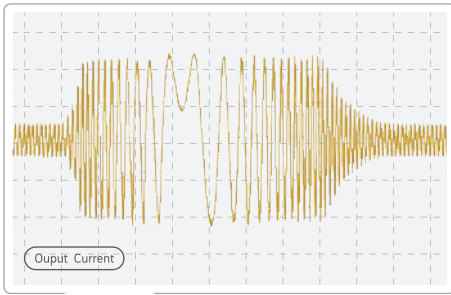

12

Short dead time between forward and reverse

Even at the setting of deceleration and acceleration time 0.1 sec-ond, a KD700 drive can smoothly complete the transition between forward and reverse, popular at applications requiring frequent and fast switchover between forward and reverse.

13

Preeminent field-weakening control

Equipped with field-weakening control, KD700 drives have the preeminent output torque and ramp character.

14

V/Hz separated control

Output voltage and output frequency can be controlled separately for the KD700 drives, widely used at variable frequency power sources, torque motors, etc.

Multifunctional and Versatile

15

Modular, flexible and adaptable

KD700 on the basis of modular design concept aims to provide users multifunctional control for a wide variety of general purpose applications. Function alities, and output capability of KD700 have been proved to meet the requirements of a vast majority of industrial control. K-DRIVE is providing KD700 single-phase 220V, three-phase 220V to 690V input, and power ratings 0.4kW up to 1MW, which means that system designers, OEMs and end users are free to connect the drive to their chosen motor and have confidence that the system will operate to the highest possible standards.

NOTE: Only 0.4 kW-560kW are listed here. Please contact K-DRIVE for more information of other power ratings.

Up to 1MW



FULL-CYCLE TESTING



During product development, the whole PCB board will be systematically tested. After assembly, the whole machine will be tested and the EMC environment will be tested. After passing the quality inspection, a 12-hour, 50°C high-temperature aging test will be performed to ensure the delivery quality of the entire series of products.

TENSION CONTROL METHOD

Speed control: Tension position feedback automatically adjusts the PID output speed slip to ensure constant material tension;

Open-loop tension torque control: the inverter directly controls the motor output torque and output frequency to follow the material line speed automatically without tension feedback signal;

Closed-loop tension torque control: tension feedback signal needed and is adjusted by built-in PID to form a closed-loop tension control motor output torque, so that the material surface tension is constant.

BASIC PRINCIPLES

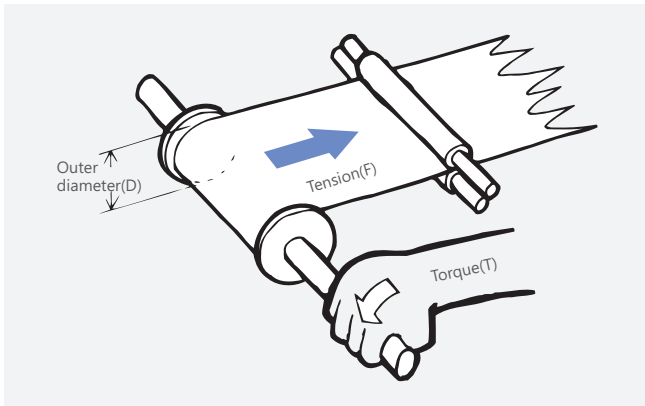

Since: $Torque(T) = Tension(F) \times Radius(D/2)$

$$\text{Therefore: tension } (F) = \frac{Torque(T)}{Radius(D/2)} = \frac{2 \times T}{D}$$

Linear Speed Method

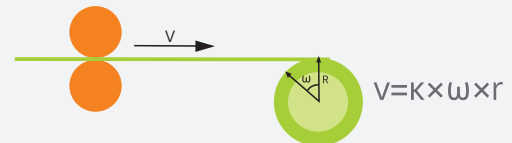

COMMON SOLUTIONS

Wire speed method:

The front-end machinery provides the material traction, which determines the material line speed, and the material tension is determined by the KD700 winding. The roll diameter can be calculated from the wire speed given by the traction.

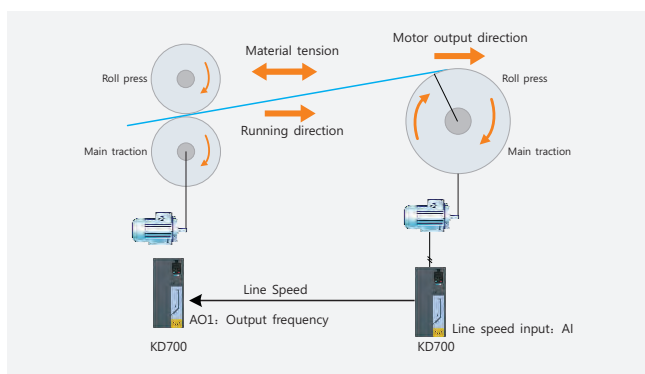

Application of the thickness method:

The front end machinery does not provide the traction mechanism to determine the line speed, the material line speed is directly determined by the front kick motor, and the material tension is determined by the KD700 winding.

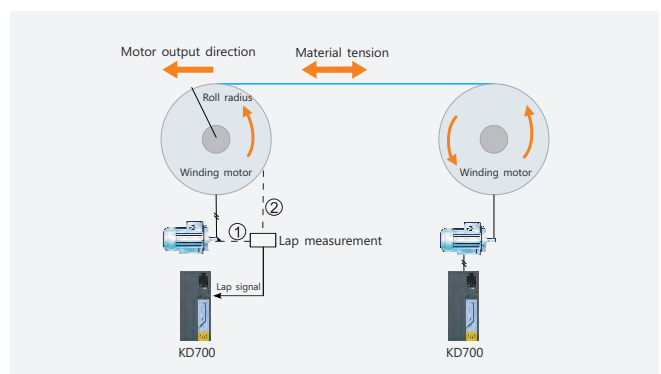

FIRE MODE IN URGENT SITUATIONS

This safety feature prevents the VFD from shutting down for self-protection. Instead, the drive will continue the vital fan operation even with a control signal, warning or alarm. Fire mode are critical to ensuring safer evacuation of people from buildings in the event of a fire.

Activating the "Fire Mode" function in K-DRIVE drives ensures safe and continuous operation in applications such as parking lot exhaust fans, smoke extraction and essential service functions.

Semi-transverse ventilation system in normal mode

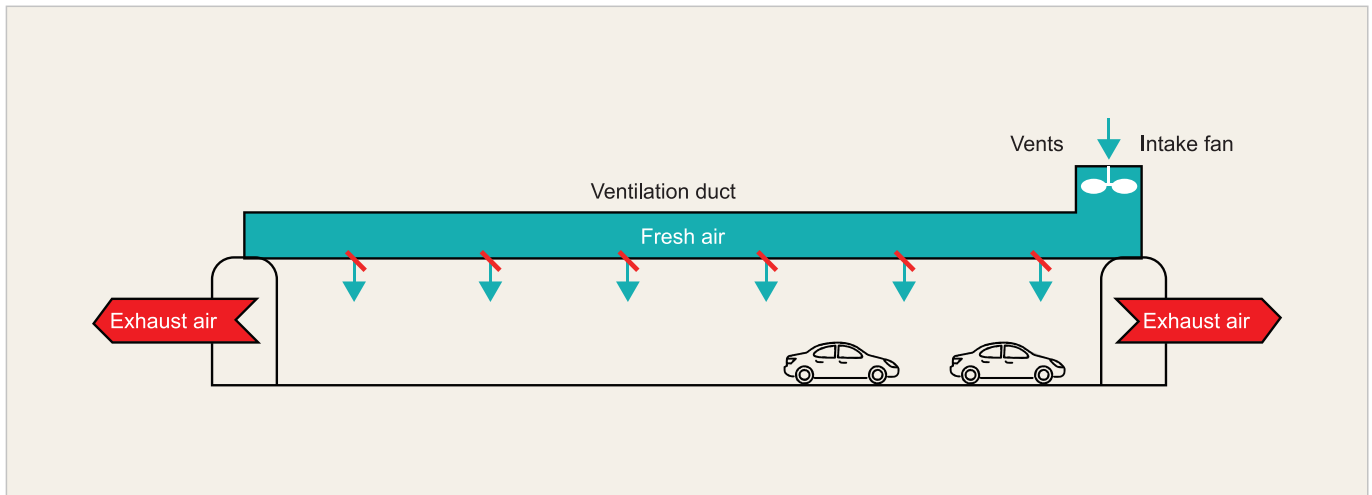

Semi-transverse ventilation system in case of fire

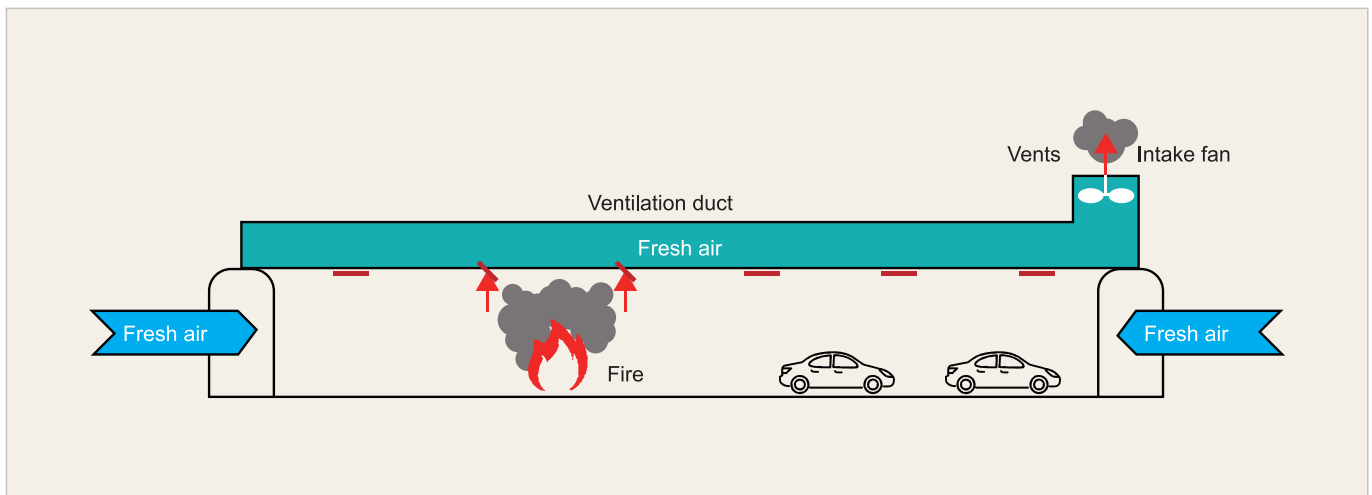

All Our Series Support Fire Mode, Including KD600M & KD700 & IP65 etc.

KD700 adopts modular design, and the control board and drive board are independent modules. There is no need for screws and cables to connect them, which can greatly simplify the after-sales workload and solve customer problems more quickly. For example, if the customer's vfd has a problem, you only need to disassemble the control board base and the entire module, without screwing or disassembling the cables, which is very convenient.



- ☑ One click parameter download and upload;
- ☑ Full color LCD keyboard with built-in multiple languages (Chinese, English, Russian);
- ☑ Support customization of monitoring pages, which can be locally plugged in or externally wired.

TECHNICAL SPECIFICATION

Project		Description
Control characteristics	Highest frequency	Vector control: 0 ~ 600Hz VF control: 0 ~ 1200Hz
	Carrier frequency	1K ~ 16kHz; the carrier frequency can be adjusted automatically according to the load characteristics.
	Input frequency resolution	Digital setting: 0.01Hz Analog setting: maximum frequency × 0.1%
	Control mode	V/F control; Open loop vector control (SVC); Closed loop vector control (FVC)
	Motor type	Asynchronous motor, permanent magnet synchronous motor
	Starting torque	G type machine: 0.5Hz/180% (Open-loop/closed-loop vector control) P type machine: 0.5Hz/120% (open loop vector control)
	Speed range	1: 200 (open-loop vector control); 1: 1000 (closed-loop vector control);
	Textile swing frequency control	Multiple triangular wave frequency control functions
	Fixed length control function	Built in fixed length control module
	Quick current limiting function	Built in fast current limiting algorithm reduces the probability of overcurrent reporting in the frequency converter and improves the overall anti-interference ability of the machine
	Timed control	Timer control function: Set time range from 0h to 65535h
	Standardization of keyboard extension cords	Customers can extend the keyboard using standard Ethernet cables on their own.
	Run Command Channel	Three channels: operation panel given, control terminal given, and serial communication port given. Can be switched in multiple ways
	Frequency source	There are a total of 10 frequency sources: digital given, analog voltage given, analog current given, pulse given, and serial port given. Can be switched in multiple ways
Auxiliary frequency source	Synchronous and asynchronous integration, combining heavy and light loads	
Functional characteristics	Synchronous and asynchronous integration, combining heavy and light loads Quick settings for application macros such as fire mode, elevator mode, tension control mode, etc	

TECHNICAL SPECIFICATION

	Project	Description
Input and output	External analog power supply	+10V, load capacity 100mA
	External digital power supply	+24V, load capacity 200mA
	Digital input	D1- DI7 multifunctional editable digital input terminal, HDI high-speed pulse input
	Digital output	FM, Pulse output or open collector switch output can be selected
	Digital terminal power mode	NPN or PNP can be selected
	Analog input	Two analog inputs, voltage 0-10V or current 0/4-20mA selectable
	Analog output	Two analog outputs, voltage 0-10V or current 0/4-20mA selectable
	Programmable relay output	Two relay outputs, contact capacity: 250VAC/3A or 30DC/1A
	Fire fighting mode	STO1 - +24V, STO2 - +24V
	Compatible with multiple encoders	Optional collector open circuit ABZ encoder card, differential input ABZ encoder card, sine cosine encoder card, and rotary encoder card.
	Compatible with multiple communication protocols	Standard Modbus 485 communication protocol, with optional matching resistors Optional bus modules and protocols such as Profinet, Probus, Ethercat, Can, Canopen, etc
Operation and Display	LED display	Dual digital display function parameter settings, status parameter viewing, and fault code viewing
	LCD display	Optional, language selection including Chinese/English /Russian
	Extended external display	Rj45 interface, LED or LCD selectable
	Parameter copying	Using LED LCD can achieve fast parameter replication
	Key locking and function selection	Implement partial or complete locking of keys, define the scope of action of some keys to prevent accidental operation
Protection function	Overpressure stall	Automatic control of bus voltage to prevent overvoltage faults
	Automatic current limiting protection	Automatic output current limitation to prevent overcurrent faults
	Overload pre alarm and warning	Overload early warning and protection
	Output load drop protection	Load drop alarm function
	Input and output phase loss protection	Automatic detection and alarm function for input and output phase loss
	Brake fault protection	Brake detection and alarm function
	Process PID given, feedback, loss detection	Process PID automatic identification of whether the given and feedback are lost, and loss alarm function
	Output ground short circuit protection	Effective protection function against ground short circuit output
	Output phase to phase short circuit protection	Effective protection function for output phase to phase short circuit
Environmental	Place of use	Indoor, not exposed to direct sunlight, free from dust, corrosive gases, flammable gases, oil mist, water vapor, dripping or salt, etc
	Altitude	Below 1000 meters, downgrading is required for use above 1000 meters
	Ambient temperature	-10 °C~+50 °C (ambient temperature is between 40 °C~50 °C, please reduce the rating for use)
	Humidity	Less than 95% RH, no condensation of water droplets
	Vibration	Less than 5.9 meters per second (0.6g)
	Storage temperature	-20°C ~ +60°C
	Class of pollution	Level 2 (dry, non-conductive dust pollution)
	Protection level	IP20
Standards	Product compliance with safety standards	IEC61800-5-1:2007
	The product complies with EMC standards	IEC61800-3:2005

BASIC CONNECTION

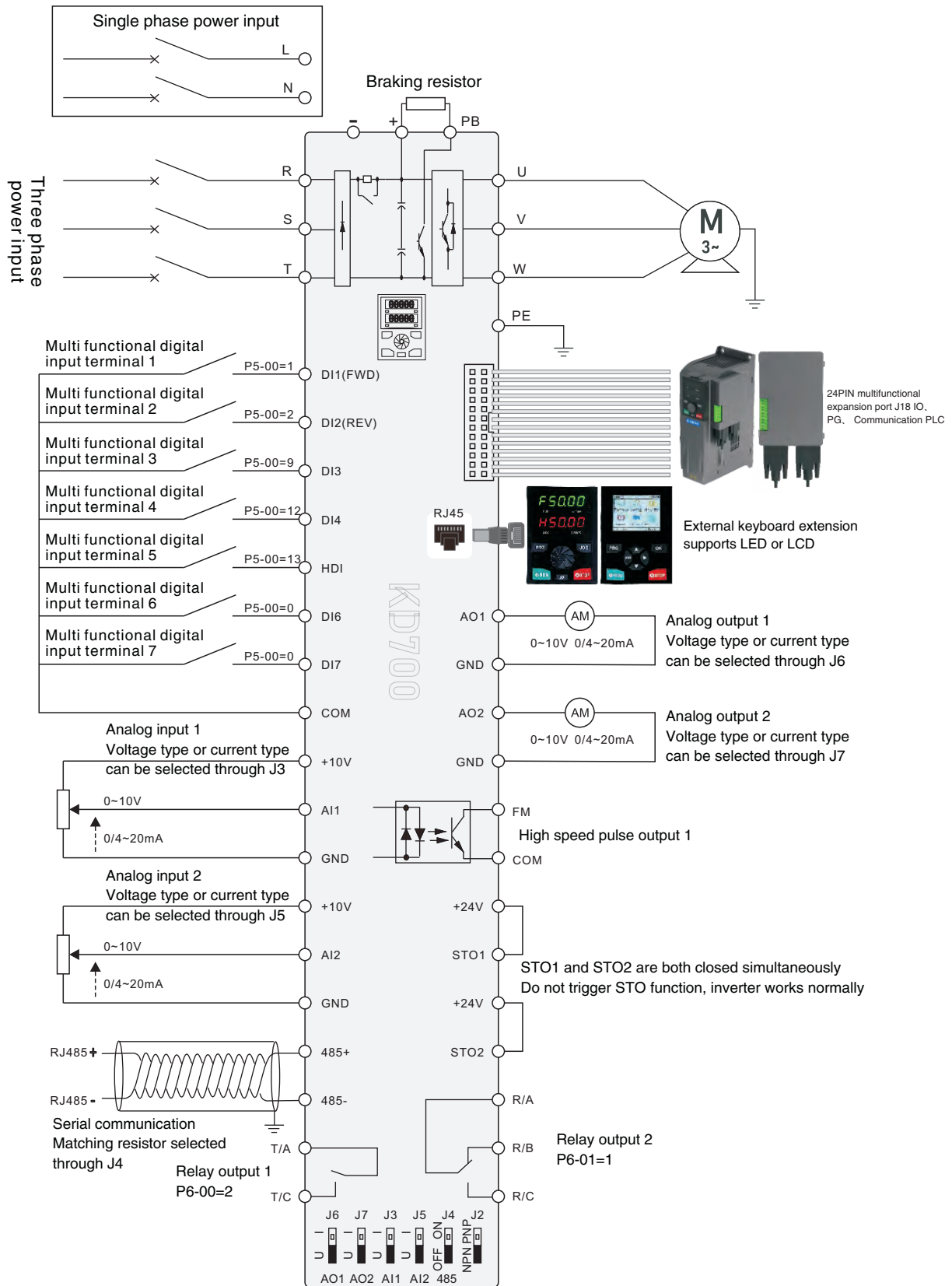

MODEL AND SIZE

A

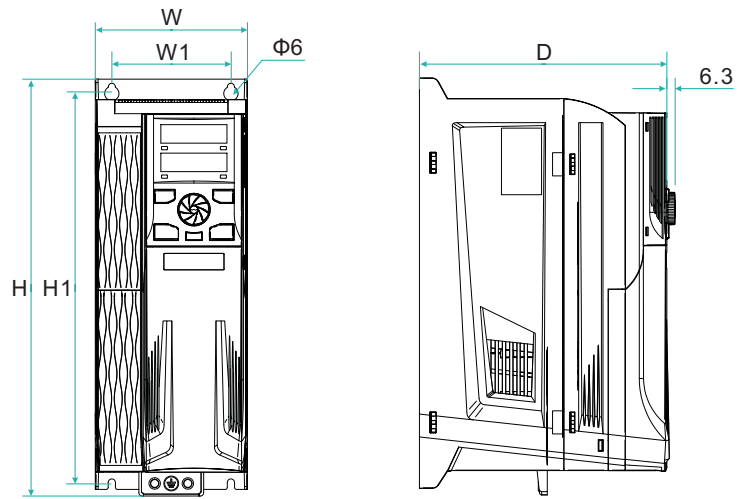

B

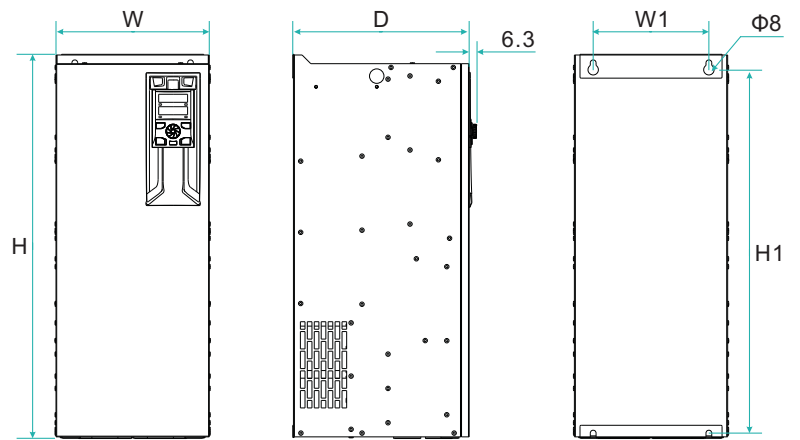

C

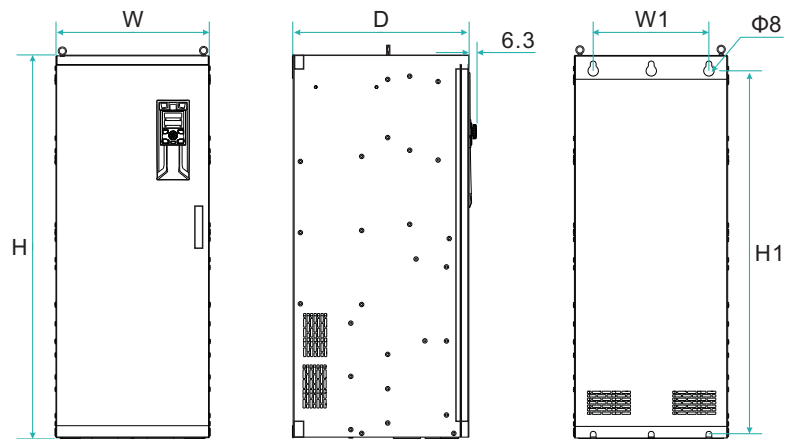



MODEL AND SIZE

2S

AC Drive Model	Adapter motor (KW)	Rated capacity (KVA)	Rated Input Current (A)	Rated Output Current(A)	Installation size(mm)		Dimensions (mm)			Aperture d	Frame NO.
					W1	H1	W	H	D		
Input voltage: single-phase 220V					Range : -15%~20%						
KD700-2S-0.4GB	0.4	1	5.4	2.3	66	190	80	200	138	4.5	
KD700-2S-0.75GB	0.75	1.5	8.2	4							
KD700-2S-1.5GB	1.5	2.8	14	7							
KD700-2S-2.2GB	2.2	3.8	23	9.6	80	250	98	260	170	4.5	
KD700-2S-4.0GB	4.0	5.9	40	17	90	300	115	310	187	5.5	
KD700-2S-5.5GB	5.5	8.5	60	25							
KD700-2S-7.5GB	7.5	10.5	75	32							

2T

AC Drive Model	Adapter motor (KW)	Rated capacity (KVA)	Rated Input Current(A)	Rated Output Current(A)	Installation size(mm)		Dimensions (mm)			Aperture d	Frame NO.
					W1	H1	W	H	D		
Input voltage: three-phase 220V					Range: -15%~20%						
KD700-2T-0.4GB	0.4	1	2.7	2.1	66	190	80	200	138	4.5	
KD700-2T-0.7GB	0.7	1.5	4.2	3.8							
KD700-2T-1.5GB	1.5	2.8	7.7	7							
KD700-2T-2.2GB	2.2	3.8	12	9	80	250	98	260	170	4.5	
KD700-2T-4.0GB	4.0	5.9	19	17	90	300	115	310	187	5.5	
KD700-2T-5.5GB	5.5	8.5	28	25							
KD700-2T-7.5GB	7.5	10.5	35	32							
KD700-2T-11GB	11	14.5	47	45	140	384	165	395	210	6	
KD700-2T-15GB	15	19.5	65	60	160	425	220	440	220	7	
KD700-2T-18.5GB	18.5	24	80	75							
KD700-2T-22G	22	28.5	97	90							
KD700-2T-30G	30	39	115	110	200	640	265	660	305	10	
KD700-2T-37G	37	48	166	152	200	765	300	785	305	10	
KD700-2T-45G	45	58.5	190	176							
KD700-2T-55G	55	71.5	214	210							
KD700-2T-75G	75	97.5	307	304	280	815	340	835	325	10	
KD700-2T-93G	93	121	389	377	300	895	410	915	370	12	
KD700-2T-110G	110	143	435	426							
KD700-2T-132G	132	171.5	468	465							
KD700-2T-160G	160	208	590	585	320	995	470	1015	385	12	
KD700-2T-200G	200	260	785	725							
KD700-2T-220G	220	286	883	820							
KD700-2T-200G	200	260	785	725	500	1115	640	1135	395	12	

4T

AC Drive Model	Adapter motor (KW)	Rated capacity (KVA)	Rated Input Current (A)	Rated Output Current (A)	Installation size (mm)		Dimensions (mm)			Aperture d	Frame NO.
					W1	H1	W	H	D		
Input voltage: three-phase 380V					Range: -15%~20%						
KD700-4T-0.7GB/1.5PB	0.7	1.5/2.5	3.4/5	2.1/3.8	66	190	80	200	138	4.5	A
KD700-4T-1.5GB/2.2PB	1.5	2.5/3.4	5/5.8	3.8/5.1							
KD700-4T-2.2GB/4.0PB	2.2	3.4/5.9	5.8/10.5	5.1/9							
KD700-4T-4.0GB/5.5PB	4.0	5.9/8.5	10.5/14.6	9/13	80	250	98	260	170	4.5	
KD700-4T-5.5GB/7.5PB	5.5	8.5/11	14.6/20.5	13/17							
KD700-4T-7.5GB/11PB	7.5	11/13.5	20.5/26	17/25	90	300	115	310	187	5.5	
KD700-4T-11GB/15PB	11	13.5/16	26/35	25/32							
KD700-4T-15GB/18.5PB	15	16/21	35/38.5	32/37	140	384	165	395	210	6	
KD700-4T-18.5GB/22PB	18.5	21/24	38.5/46.5	37/45							
KD700-4T-22GB/30PB	22	24/30	46.5/62	45/60	160	425	220	440	220	7	
KD700-4T-30GB/37PB	30	30/39	62/76	60/75							
KD700-4T-37GB/45PB	37	39/49	76/92	75/90	160	535	145	550	255	7	
KD700-4T-45G(B)/55P(B)	45	49/59	92/113	90/110							
KD700-4T-55G(B)/75P(B)	55	59/72	113/157	110/152	200	640	265	660	305	10	
KD700-4T-75G(B)/93P(B)	75	72/100	157/180	152/176							
KD700-4T-93G(B)/110P(B)	90	100/116	180/214	176/210	200	765	300	785	305	10	
KD700-4T-110G(B)/132P(B)	110	116/138	214/256	210/253							
KD700-4T-132G(B)/160P(B)	132	138/167	256/307	253/304	280	815	340	835	325	10	
KD700-4T-160G(B)/185P(B)	160	167/200	307/345	304/340							
KD700-4T-185G/200P	185	200/225	345/385	340/377	300	895	410	915	370	12	
KD700-4T-200G/220P	200	225/280	385/430	377/426							
KD700-4T-220G/250P	220	280/309	430/468	426/465	320	995	470	1015	385	12	
KD700-4T-250G/280P	250	309/349	468/525	465/520							
KD700-4T-280G/315P	280	349/398	525/590	520/585	500	1115	640	1135	395	12	
KD700-4T-315G/355P	315	398/434	590/665	585/650							
KD700-4T-355G/400P	350	434/494	665/785	650/725	500	1115	640	1135	395	12	
KD700-4T-400G/450P	400	494/560	785/883	725/820							
KD700-4T-450G/500P	450	560/615	883/920	820/900	500	1115	640	1135	395	12	
KD700-4T-500G/550P	500	615/676	920/1020	900/1000							
KD700-4T-550G/630P	550	676/775	1020/1120	1000/1100	/	/	800	1800	500	Vertical	
KD700-4T-630G	630	775	1200	1150	/	/	1100	2200	600	Vertical	
KD700-4T-710G	710	870	1315	1250							
KD700-4T-800G	800	980	1560	1450	/	/	1300	2300	600	Vertical	
KD700-4T-900G	710	1100	1760	1710							
KD700-4T-1000G	800	1230	1960	1900	/	/	1300	2300	600	Vertical	

KD700 Series Boost inverter

AC Drive Model	Adapter motor (KW)	Rated capacity (KVA)	Rated Input Current (A)	Rated Output Current (A)	Installation size (mm)		Dimensions (mm)			Aperture d	Frame NO.
					W1	H1	W	H	D		
2S/4T 220V Single phase input & 380V Three Phase output											
KD700-2S/4T-0.75G	0.75	2.5	7.3	2.3	66	190	80	200	138	4.5	
KD700-2S/4T-1.5G	1.5	3.4	13.3	3.8							
KD700-2S/4T-2.2G	2.2	5.9	17.9	5.1	80	250	98	260	170	4.5	
KD700-2S/4T-3.7G	3.7	8.5	31.5	9							
KD700-2S/4T-5.5G	5.5	13.5	45.5	13	90	300	115	310	187	5.5	
KD700-2S/4T-7.5G	7.5	16	59.5	17							
KD700-2S/4T-11G	11	16	87.5	25							
KD700-2S/4T-15G	15	21	112	32	140	384	165	395	210	6	
KD700-2S/4T-18.5G	18.5	24	129.5	37							
KD700-2S/4T-22G	22	30	157.5	45	160	425	220	440	220	7	
KD700-2S/4T-30G	30	39/49	210	60							
KD700-2S/4T-37G	37	49/59	262.5	75							

KD700-2SS Series

AC Drive Model	Adapter motor (KW)	Rated capacity (KVA)	Rated Input Current (A)	Rated Output Current (A)	Installation size (mm)		Dimensions (mm)			Aperture d	Frame NO.
					W1	H1	W	H	D		
2SS 220V Single Phase Input & Single Phase Output											
KD700-2SS-1.5G	1.5	2.5	7.6	7	66	190	80	200	138	4.5	
KD700-2SS-2.2G	2.2	3.4	12	9.6							
KD700-2SS-4.0G	4.0	8.5	19	17	80	250	98	260	170	4.5	
KD700-2SS-5.5G	5.5	13.5	28	25							
KD700-2SS-7.5G	7.5	16	35	32	90	300	115	310	187	5.5	
KD700-2SS-11G	11	21	47	45							
KD700-2SS-15G	15	30	65	60							

K-DRIVE
AC DRIVE

ELEVATOR
THE POWER



KD700E

Dedicated AC Drive

For elevator, escalator and hoist

KD700E are specific for passenger and freight elevators installed in residential buildings, shopping malls, and office buildings. The drives can be programmed to have a commendable leveling even they adopt open-loop control, reducing the cost of additional devices. Flexible S-curve program greatly improves comfortability for the elevator users. All elevator parameters gathered in one chapter in the user manual, and well furnished parameter default values make the commissioning easy and fast.

COMPATIBILITY

Asynch motor control applicable
Synchronous motor Control

POWER RATINGS

1×220 - 240V	0.4 - 75kW
3×380 - 480V	0.75 - 800kW

CONTROL TECHNOLOGY

V/Hz SVC1 SVC2

FEATURES

01 Safety and reliability

Safety at KD700E has the highest priority since we understand they are dedicated for passenger elevators. Through enable signal, the drive will enable the run of the motor only when the motor run contactor, all safety contactors are well closed. 220V AC UPS power supply, emergency speed, and inspection speed are supported or programmable at KD700E series, a full coverage on the safety requirement at the drive side.

UPS
applicable

02 Dedicated control sequence

Lift dedicated control sequence, big output torque at low frequency of V/Hz mode, and fast response time make the elevator motion stable and smooth.



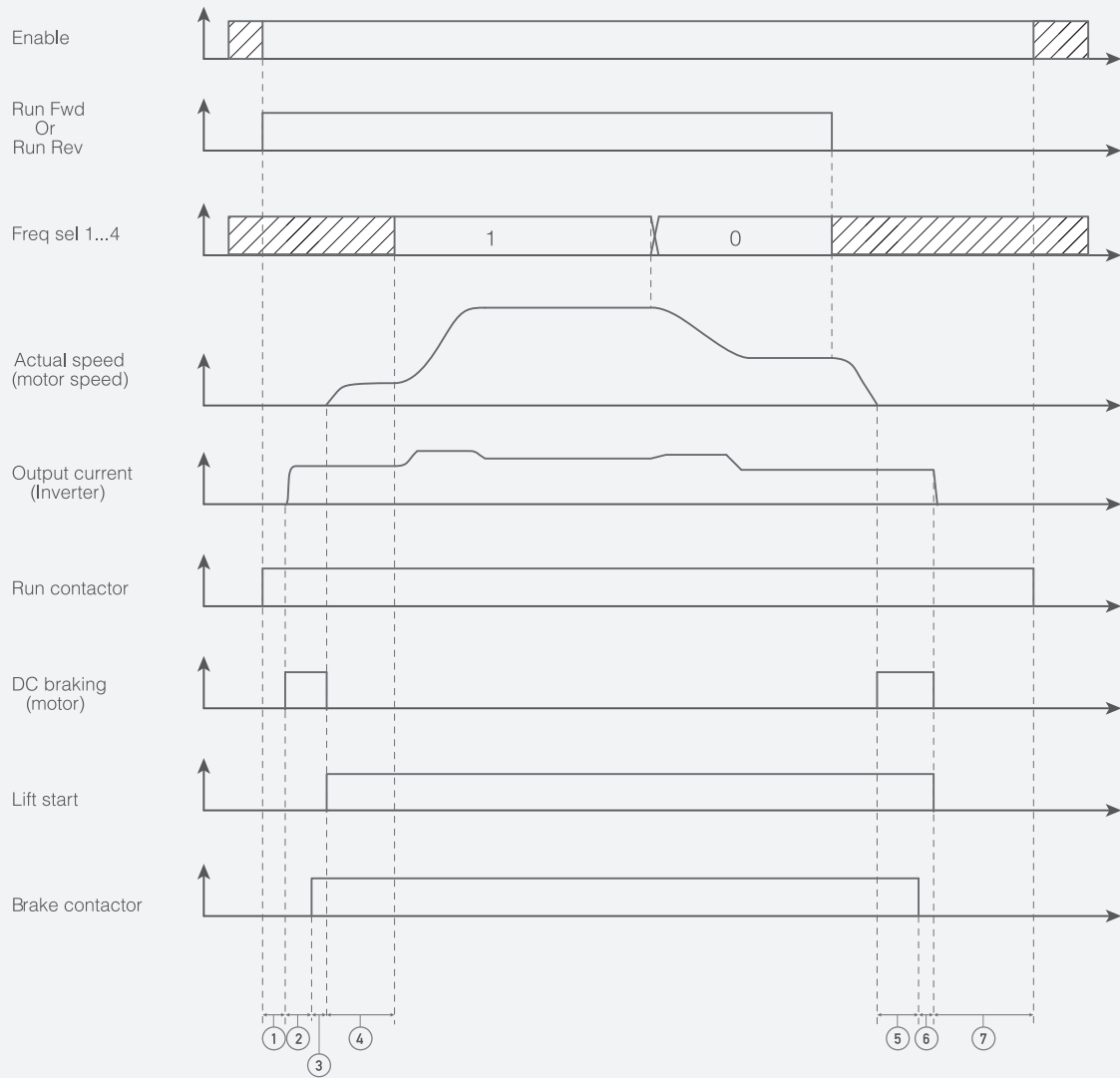

- ① Cont close delay
- ② Magnet time
- ③ Brake open delay
- ④ Smooth start delay
- ⑤ Brake waiting time
- ⑥ Brake close delay
- ⑦ Cont open delay

03 Commendable leveling

Fast response time, programmable S-curve, slip compensation separated for elevator uplink or downlink make the car a commendable leveling for different motor brands.



04

Silky smoothness

Smoothness at the start and stop is quite important and the main reason for the users to select the drive or not. KD700E have a lot of approaches to program the smoothness at the start and stop, like smooth start frequency, DC injection brake, torque boost, V/Hz mode, brake sequency, and so forth.

05

Emergency and inspection speed programmable

If the grid power supply is suddenly lost, the drive will get into emergency mode and run at the emergency speed via UPS power supply. Inspection speed can also be programmed via multi-speed selections.

06

STO Function Built In

Compliant with IEC 62061-SIL3,Enhancing safety by immediately shutting off torque output to the connected motor, making it an effective measure for preventing accidents in industrial settings.

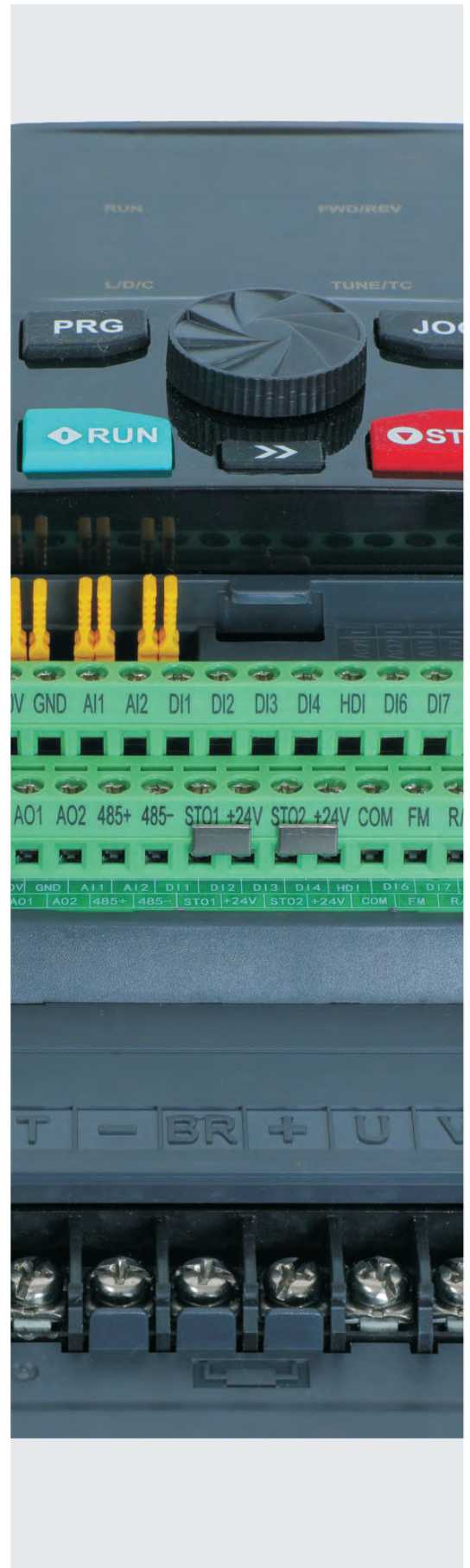
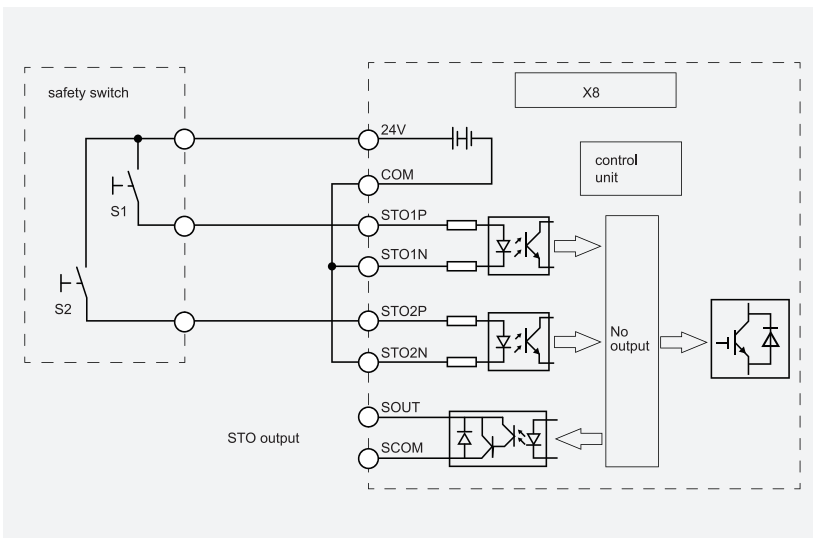

BASIC CONNECTION

Following is the default wiring diagram for KD700E. Please consult K-DRIVE if customized solution is required.

SINGLE MULTI-SPEED TERMINAL ELEVATOR CONTROLLER

For the elevator controller with only one multi-segment speed changing terminal, the high-speed segment and the layer speed segment are controlled by the on-off of the high-speed terminal. The wiring diagram of such elevator controller and frequency converter is as follows:

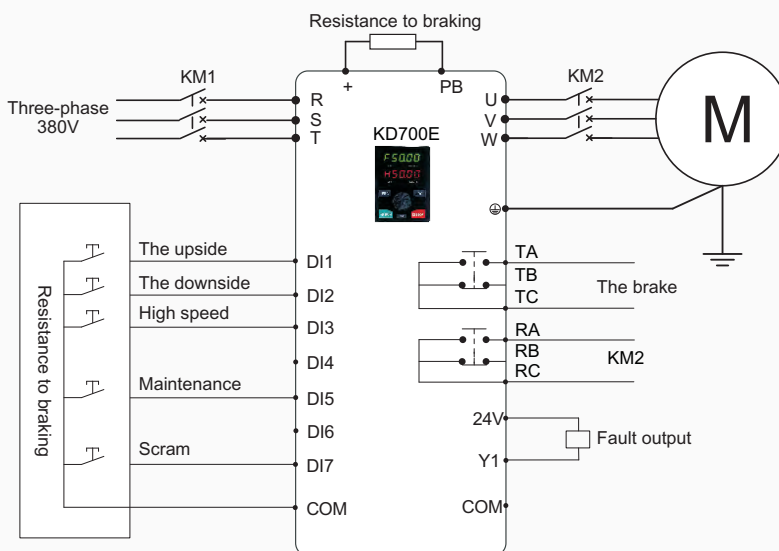

DOUBLE MULTI-SPEED TERMINAL ELEVATOR CONTROLLER

For the elevator controller with two multi-speed changing terminals, its high speed is controlled by the on-off of one terminal, and the other terminal is to control the flat speed or zero speed according to different controllers. The wiring diagram of the elevator controller and frequency converter with two multi-speed terminals is as follows:

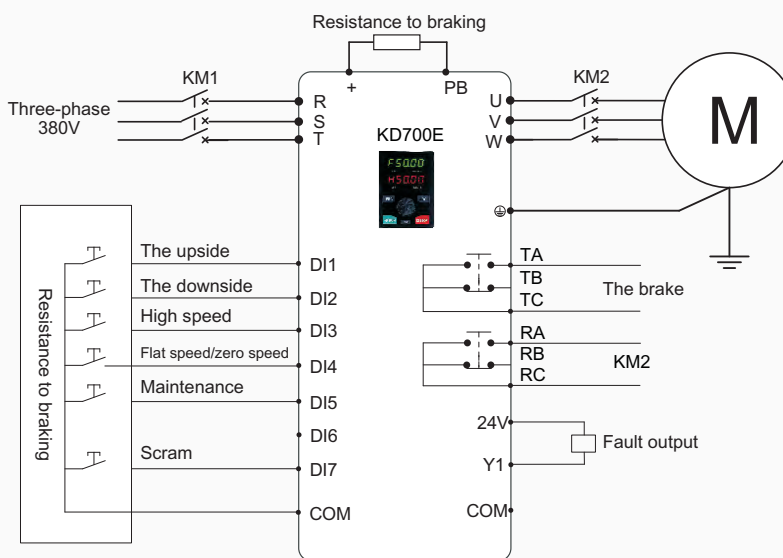

EMERGENCY OPERATION MODE

When the elevator is in use, if the system's power supply suddenly fails, it may result in passengers being locked in the car. KD700E series elevator inverter can support the emergency UPS power supply operation for emergency power outage operation, and the emergency signal can be received by the inverter terminal DI6. The wiring diagram is as follows:

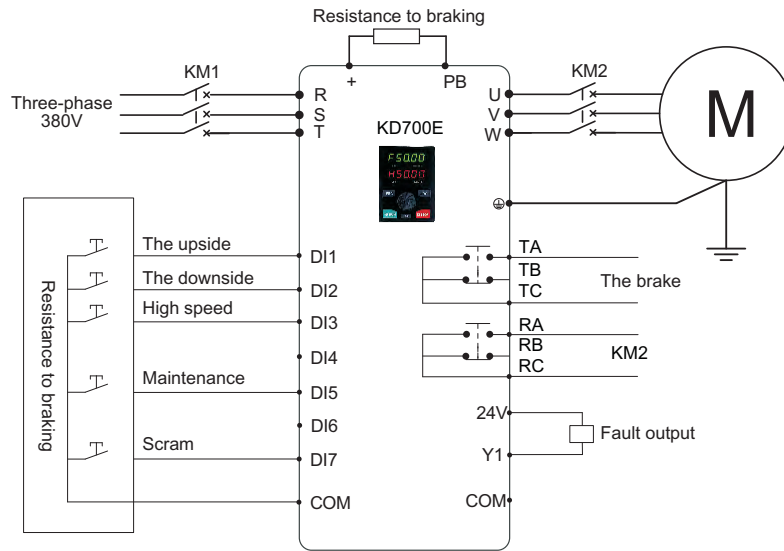

CLOSED LOOP ELEVATOR CONTROL

KD700E series elevator inverter can support closed-loop control, and provides a variety of PG cards for use with different encoders. Please refer to Chapter 5 of KD600 series User manual for PG card information. The wiring diagram of elevator controller and frequency converter for closed-loop elevator control is shown in the following figure:

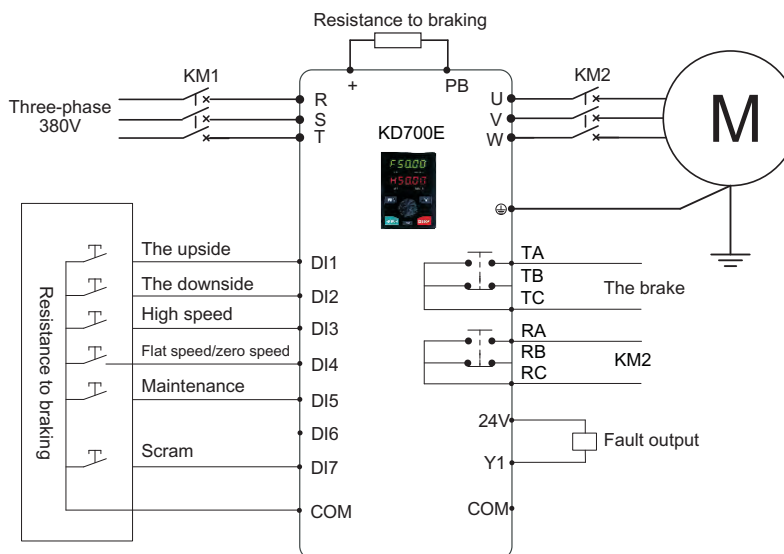

K-DRIVE
AC DRIVE



CRANE



KD700C

Crane specific AC Drive

The KD700C series hoisting inverter is a special software integrated in our general purpose KD700 model, just need simply change a parameter to use it. This series integrates a variety of industry application functions including brake control, anti-hook detection, light load speed increase and heavy load speed reduction, zero servo, crane travel anti-sway and tower crane rotation, etc., to ensure the safety, reliability and efficient operation of the lifting equipment.

This product adopts international leading control technology, and its performance reaches the level of international high-end inverters, supporting induction motor and permanent magnet synchronous motor drive. It is equipped with a variety of expansion cards such as PG card, communication card I/O expansion card to meet diverse application needs. The product has a high power density design, and some power segments have built-in braking units to save installation space. At the same time, the product meets the environmental protection requirements of low noise and low electromagnetic interference through electromagnetic compatibility optimization design, and has the ability to adapt to harsh power grids, temperature, humidity and dust environments, which significantly improves product reliability.

KD700C series products have been widely used in general lifting equipment (gantry cranes, European cranes, various types of hoists, etc.), port lifting equipment (shore cranes, yard cranes, portal cranes, tipping container spreaders, etc.), construction lifting equipment (tower cranes, construction elevators, etc.), and mining lifting equipment (mine hoists, winches, belt conveyors, etc.).

COMPATIBILITY

Asynch motor control applicable
Synchronous motor Control

POWER RATINGS

1×220 - 240V	0.4 - 75kW
3×380 - 480V	0.75 - 800kW

CONTROL TECHNOLOGY

V/Hz SVC1 SVC2



Leading technology, improving efficiency

01

Professional brake timing control

The frequency converter will only activate the brake when both the frequency and current of the release/hold brake are met, and a delay before and after releasing/reporting the brake is added to ensure the safe and smooth start and stop of the equipment;

Under the precise control of closed-loop vectors, a pre torque current is output before releasing/reporting the brake to activate the brake. With a delay before and after releasing/reporting, the equipment is ensured to start and stop safely and smoothly.

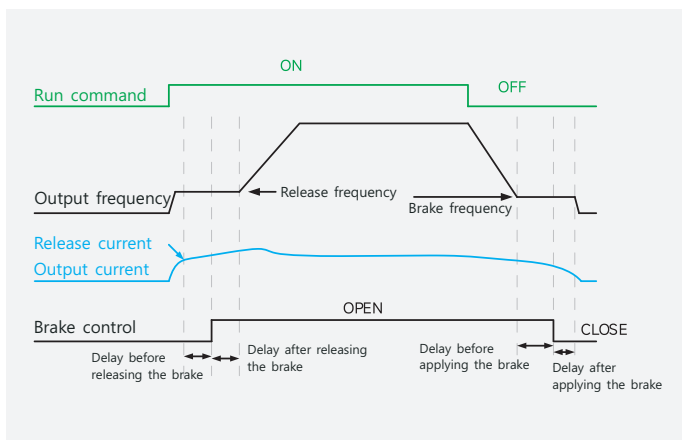

Open loop lifting control timing diagram

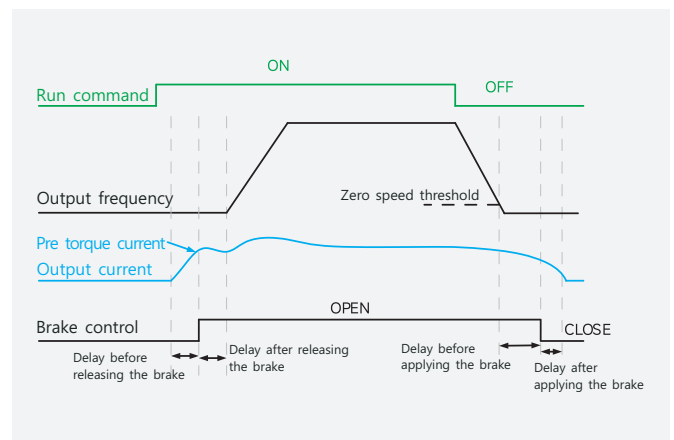

Closed loop lifting control timing diagram

02

Integrate anti sway technology for both large and small vehicles to improve equipment efficiency

Built in anti sway algorithm for large and small vehicles, which can effectively reduce the amplitude of cargo swinging during their movement, improve work efficiency and safety.

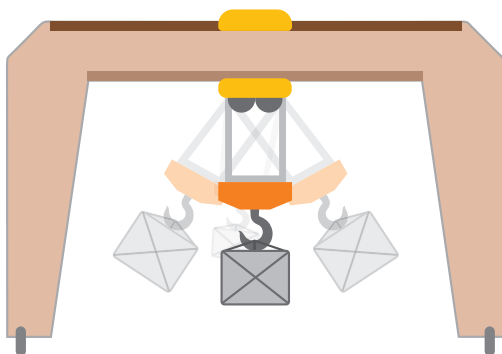

The anti sway function is not turned on

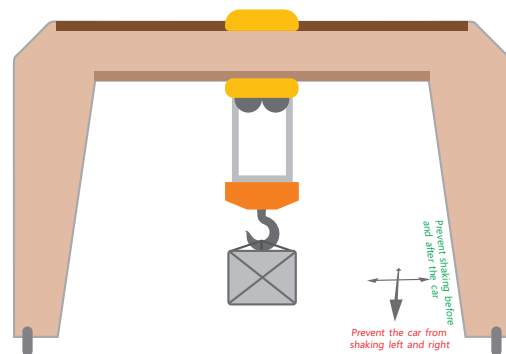

Anti sway function activated

03

Zero servo function ensures safe use

When the equipment is running, if there is a mechanical brake failure, inability to hold the brake in a timely manner, or inability to hold it tightly, the frequency converter immediately detects the rotation of the motor shaft and activates the zero servo function when it is powered on, causing the cargo or car to hover in the current position, while issuing an alarm to prompt the operators to take corresponding measures and provide safety protection for the operation of the equipment.



04

Intelligent anti roll algorithm, starting torque $\geq 150\%$, effectively avoiding the phenomenon of starting roll

Built in intelligent anti slip algorithm can achieve a 0.0Hz output of 150%+rated torque, and can operate stably under load at ultra-low speeds. The anti slip algorithm can enable the equipment to start with high torque and output high torque when operating under load or no-load, effectively avoiding the phenomenon of lifting equipment slipping during ascent and descent and ensuring safe operation of the equipment.

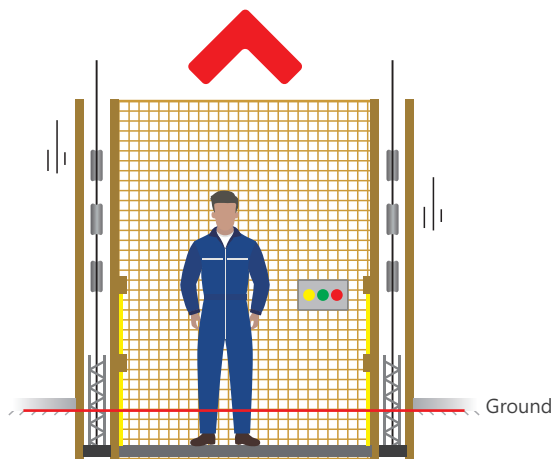

No anti slip algorithm

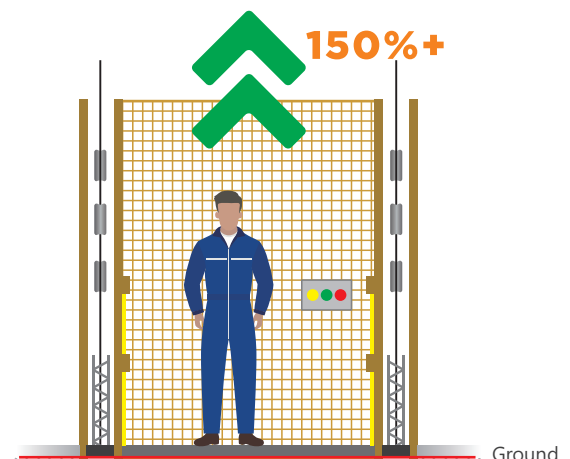

There is an anti slip algorithm

Multi mode, multi integration

05

Automatic acceleration under light load to improve efficiency, automatic deceleration under overload

Supporting constant power mode, it can automatically match the optimal operating speed according to the load situation during operation, automatically reduce speed under heavy load, and ensure the safety of goods and personnel; Automatic acceleration under light load to improve on-site operation efficiency.

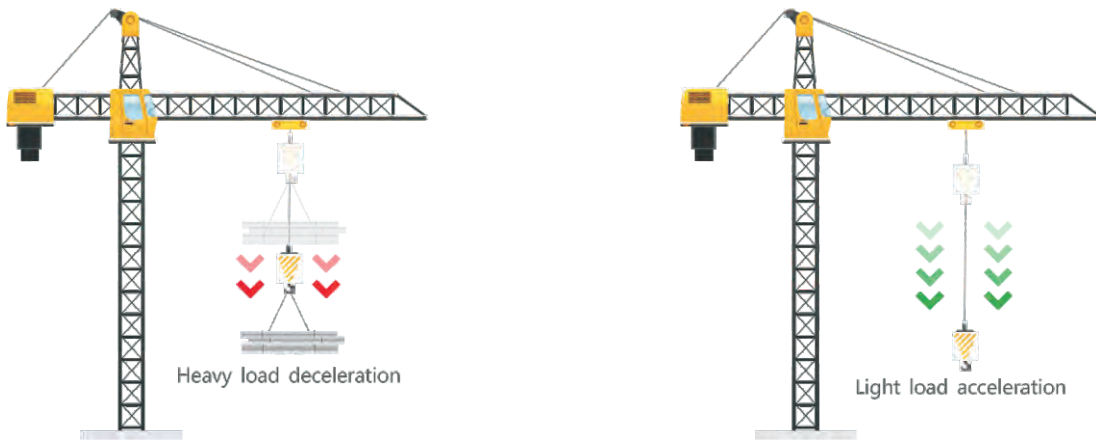

06

Smooth acceleration and deceleration, smooth and stable operation

Supports linear and S-shaped curve acceleration and deceleration, with 4 sets of acceleration and deceleration times that can be easily set to match the acceleration and deceleration characteristics of lifting, walking and translation, construction lifting, tower crane rotation, and other sections, ensuring smooth operation of each section of the lifting equipment.

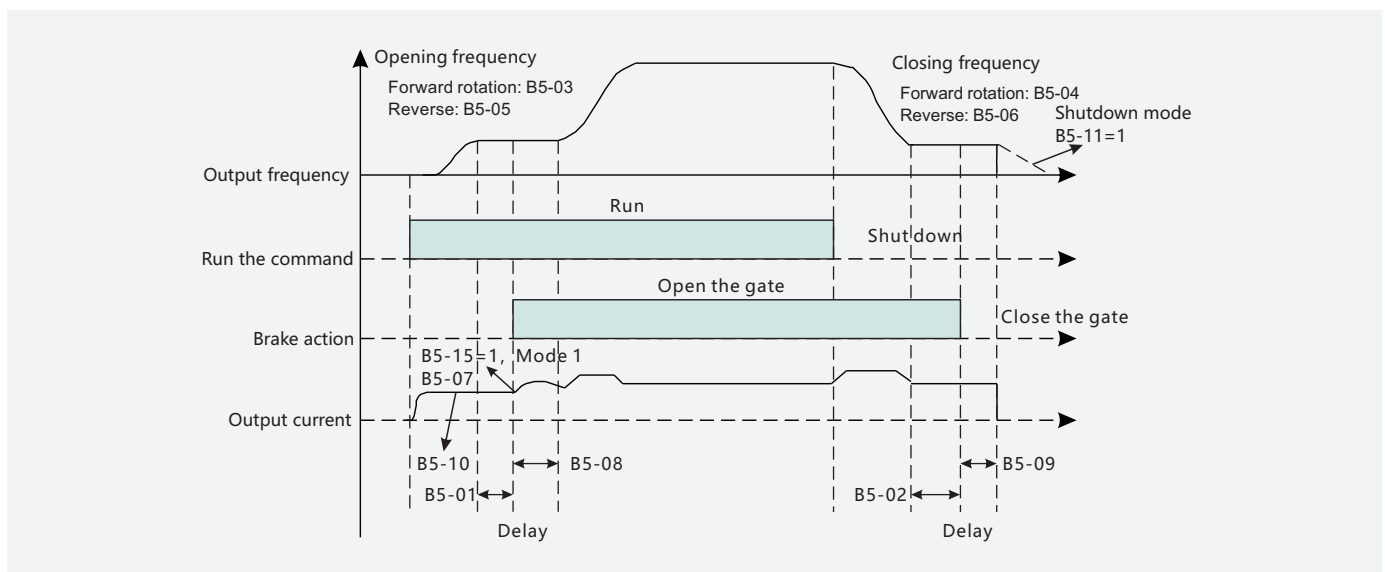

Solution

QUAY CRANE



The quay crane is a large-scale lifting equipment specifically designed for port terminals. It is installed on the shore track and efficiently loads and unloads container ships through a tall door frame structure. It has the functions of forward and backward movement and lifting, and is the core loading and unloading machinery of maritime container terminals.

Product Configuration

KD700C series lifting dedicated frequency converter

KD700 series high-performance vector frequency converter

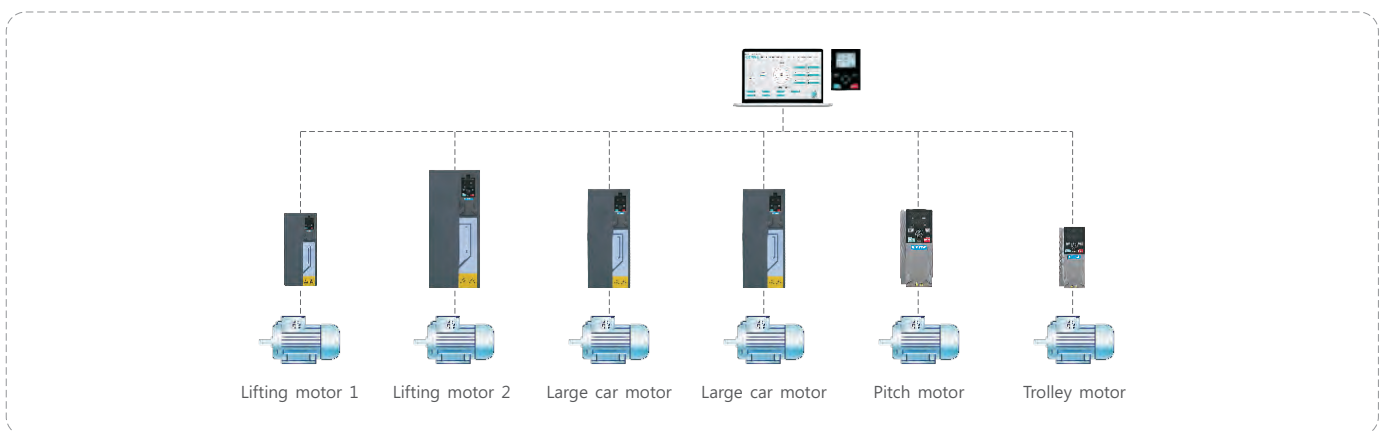

FIELD BRIDGE CRANE



The gantry crane is a specialized container equipment used in ports and logistics yards. It is divided into track type (fixed route) and tire type (flexible movement), mainly used for horizontal handling, stacking, and loading and unloading of containers. It has the ability to cross container areas and improve the efficiency of yard cargo turnover.

Product Configuration

KD700C series lifting dedicated frequency converter

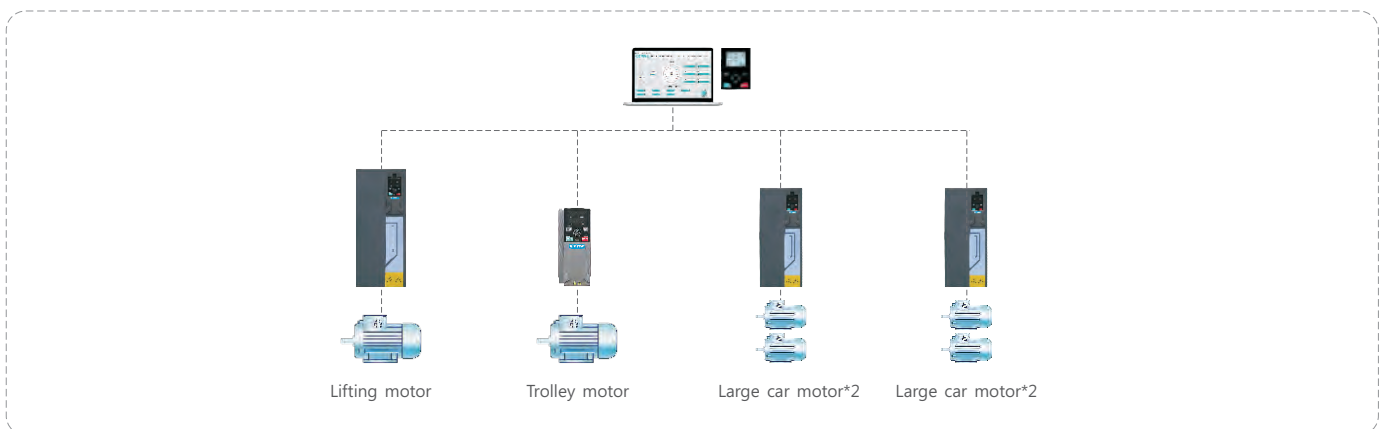

Solution

BRIDGE CRANE



Bridge crane is a lifting equipment that is horizontally mounted above indoor spaces such as workshops and warehouses. The bridge runs along the tracks on both sides and is divided into single beam (lightweight and economical), double beam (heavy load), and ordinary/European style (low clearance design). It is widely used for material lifting and can be operated in conjunction with electric hoists or winches.

Product Configuration

KD700C series lifting dedicated frequency converter

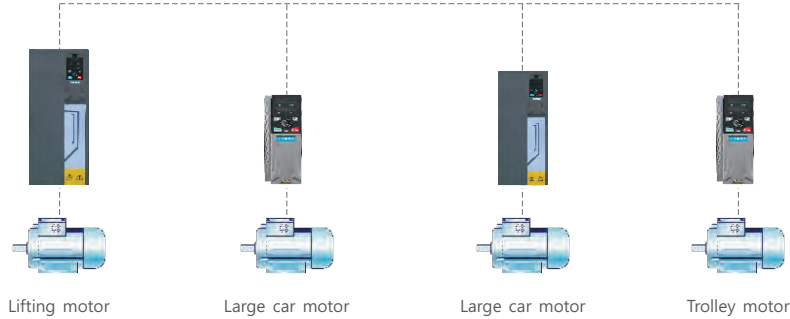

GANTRY CRANE



The gantry crane is a specialized container equipment used in ports and logistics yards. It is divided into track type (fixed route) and tire type (flexible movement), mainly used for horizontal handling, stacking, and loading and unloading of containers. It has the ability to cross container areas and improve the efficiency of yard cargo turnover.

Product Configuration

KD700C series lifting dedicated frequency converter

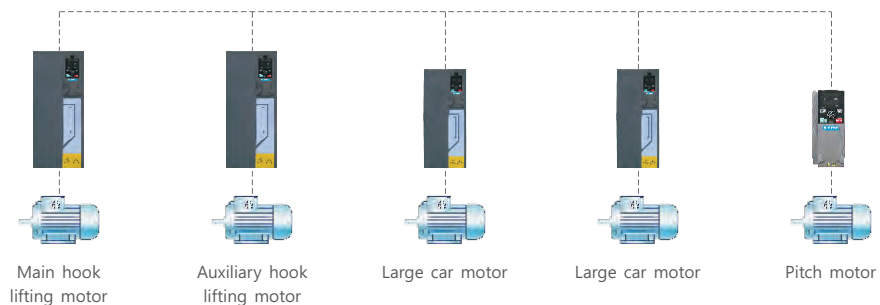

Solution

TOWER CRANE



Tower crane is a commonly used vertical transportation equipment in construction, characterized by a vertical tower body and a horizontal lifting arm. The lifting arm can rotate 360 ° and can be raised as the floor rises. It is mainly used for lifting building materials such as steel bars, concrete, and pipes in high-rise buildings, and is divided into two forms: upper rotation and lower rotation.

Product Configuration

KD700C series lifting dedicated frequency converter

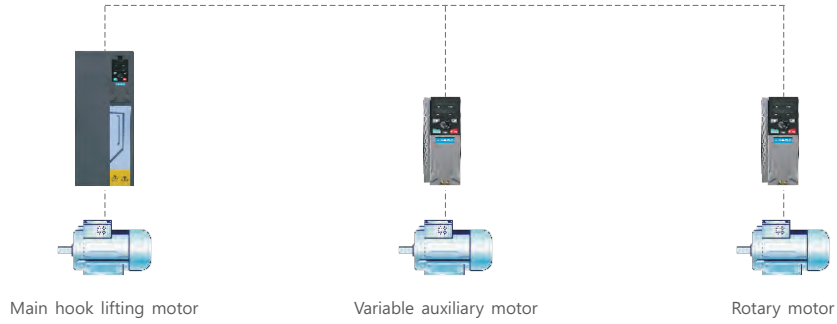

CONSTRUCTION LADDER



Construction ladder is a vertical transportation facility for personnel to go up and down in the construction site. It is mostly made of steel structure or aluminum alloy frame, equipped with protective railings and safety devices. It is divided into fixed (attached to the building) and mobile (removable and movable) to ensure the safe and convenient passage of personnel.

Product Configuration

KD700C series lifting dedicated frequency converter



K-DRIVE
AC DRIVE

STERRING
THE POWER
OF THE SUN



SP700

Dedicated AC Drive
For solar pump

SP700 dedicated AC drive is a decent solution that takes use of solar power as a green and energy source for pumping water.

COMPATIBILITY

Synch motor control applicable
Asynch motor control applicable

POWER RATINGS

150 - 400VDC / 200 - 240VAC 1Phase	0.4 - 2.2kW
250 - 800VDC / 380 - 460VAC 3Phase	0.4 - 75kW

CONTROL TECHNOLOGY

V/Hz SVC for synch motor

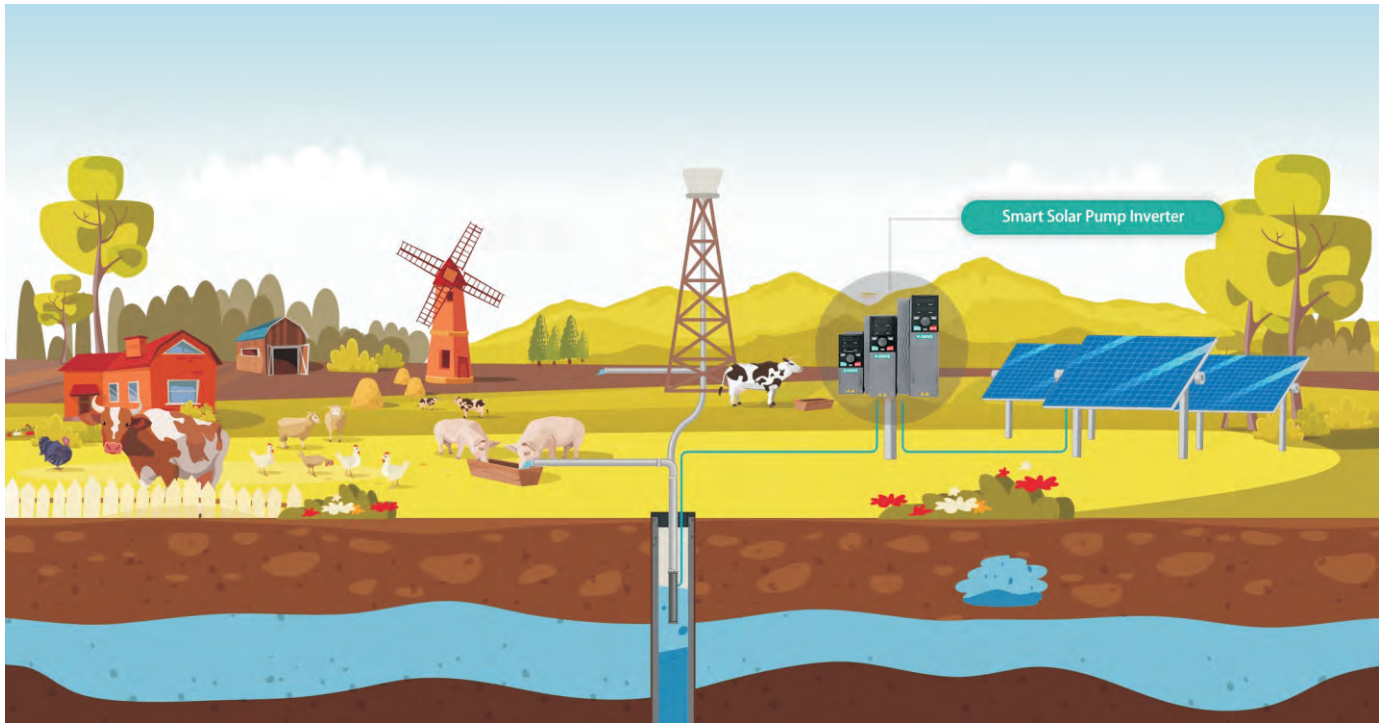

01 MPPT

The SP700 solar pump drive is tailored to effectively use the energy from the sunshine. Its inbuilt maximum power point tracking functionality always feeds the maximum amount of power possible from the panels to the pump.



02 Classified user mode

SP700 drives are equipped with three operation modes. Plug-and-Play Mode is for robust MPPT operation, while Senior Mode for the best performance of MPPT. Professional Mode is designed for the users who ask for comprehensive water supply functions.



03

Automatic run/sleep

When sunlight radiation meets the threshold requirement, a SP700 solar pump drive starts automatically, and the pump connected to it begins to run. When the sunshine is weak, the pump will fall into sleep.

**04**

Dry run protection

Dry run protection is one of quite important functionalities for automatic operation of the water pumping system, realized by K-DRIVE without requirement of signal feedback from any devices.



Flexible control mode

Pressure control mode under AC power supply from grid or diesel generator.

Users would like to use this functionality in some water supply systems, when the pressure is required to be a constant value and the drive is being connected to AC power supply from grid or diesel generator.

Constant speed mode under AC power supply

Users are most likely to use this functionality when sun radiation is not strong enough or unavailable, and the water supply system just simply requires the water to be pumped at the rated output.

Pressure limit mode under power supply from solar panels.

Users need to use this functionality in some water supply systems, when the pressure needs to be limited not to exceed a certain value.

Multistep pressure mode

This functionality is quite useful sometimes for farm irrigation when different area requires different pressures.

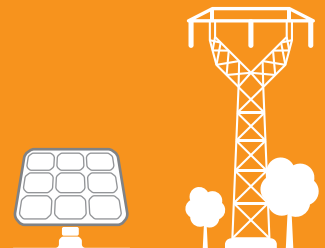

SP700-SPECIFICATION

Input Specification	2S	4T
Max. input DC voltage	450VDC	800VDC (900VDC optional)
Recommended VOC voltage range	360 ~ 430VDC	550 ~ 750VDC
Recommended MPPT voltage range	250 ~ 350VDC	450 ~ 600VDC
Starting voltage range	160-450VDC (Adjustable parameters)	250-800VDC (Adjustable parameters)
Grid or Backup Generator Input	2S	4T
Input AC voltage	Single-phase/ Three-phase 220V Range:-15% ~ 20%	Three-phase 380V Range: 15% ~ 20%
Output Specification	2S	4T
Rated output voltage AC	3PH/1PH 220V	Three-phase 380V
Output frequency range	0 ~ 500.00HZ	
Protection		
Built-in protection	Overvoltage, overcurrent, output phase loss, overload, undervoltage, short circuit,overheating, dry running of the pump under load, etc.	

Grid power supply debugging

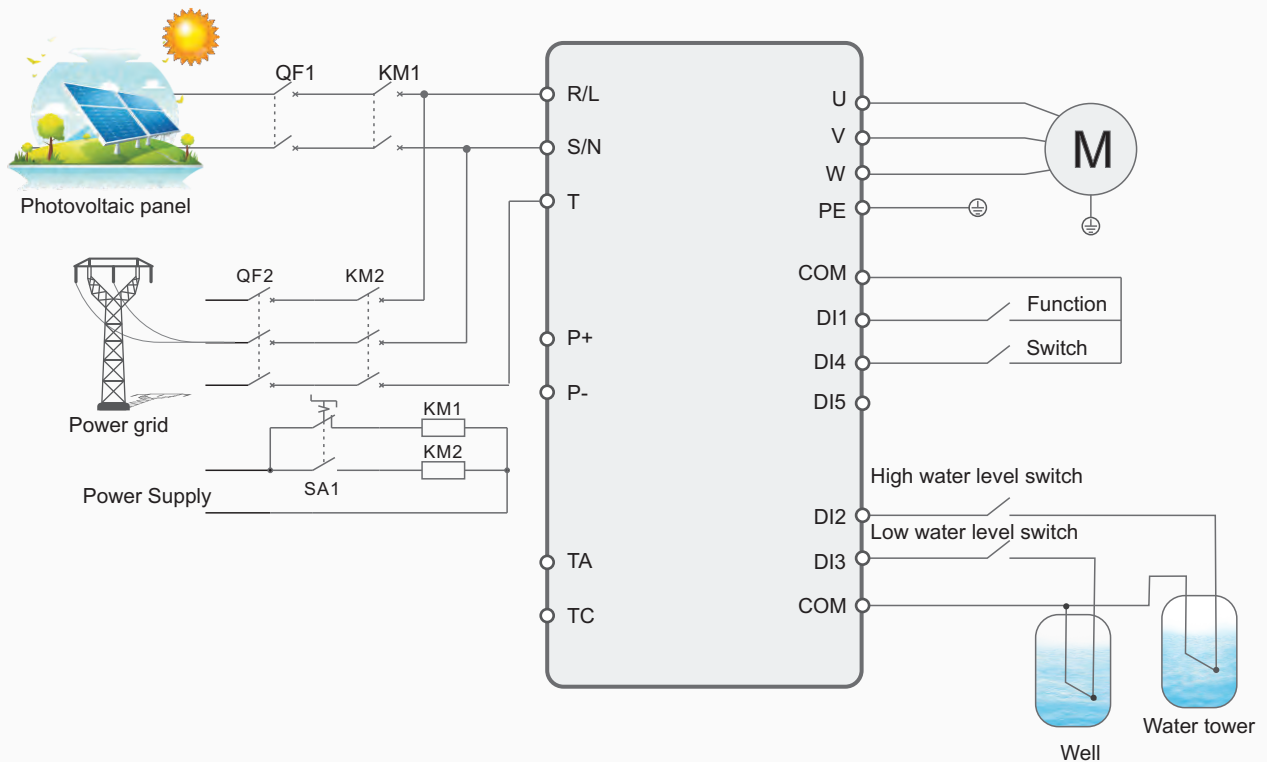

Grid power supply debugging

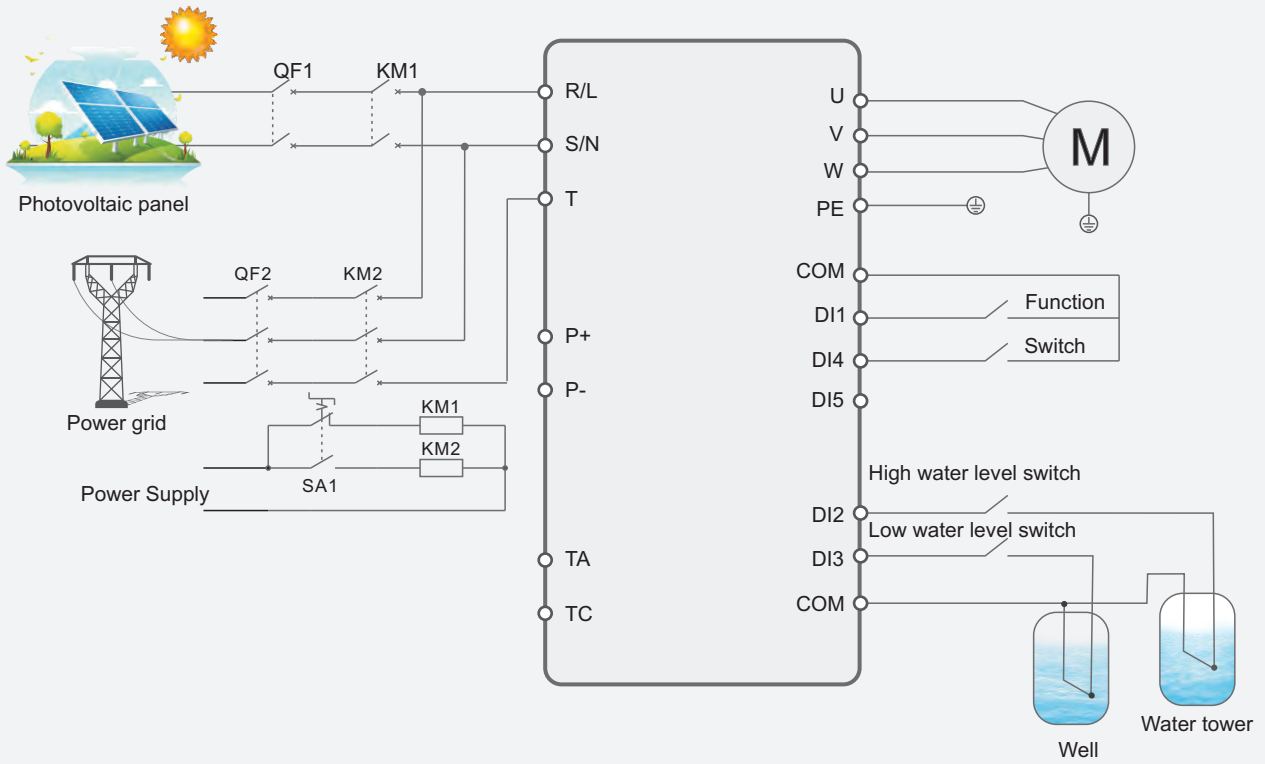

Automatic switching and debugging of photovoltaic panels and grid power supply

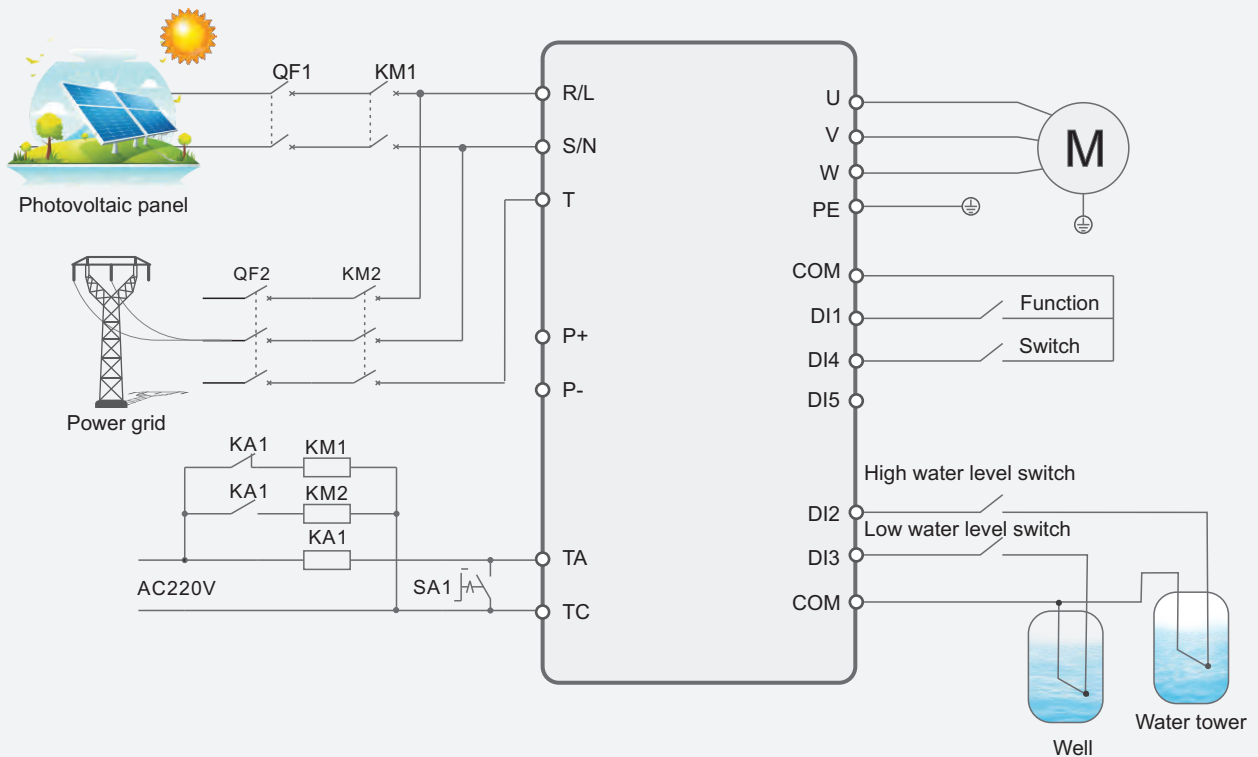

Optional GPRS monitoring device



K-DRIVE solar pump inverter GPRS system is a professional monitoring system platform managing solar pump plants.

It supplies water volume monitoring and operation of inverter from anywhere at any time.

It's convenient to visit real time and historical data via web or IOS & Android APP anytime and anywhere.

This easy-to-use platform make monitoring of solar pump systems simple and convenient, far reducing operate time and monitoring costs as well.

Installation and terminal connection

Terminal	Drive	GPRS module
Power terminal	24+	VCC
	COM	GND
Communication terminal	485+	TX1/A1+
	485-	RX1/B1-

- Iphone
- Ipad
- Android devices



Monitor and operate at anytime,from anywhere

GPRS OPERATION

Remote control and monitor from PC side

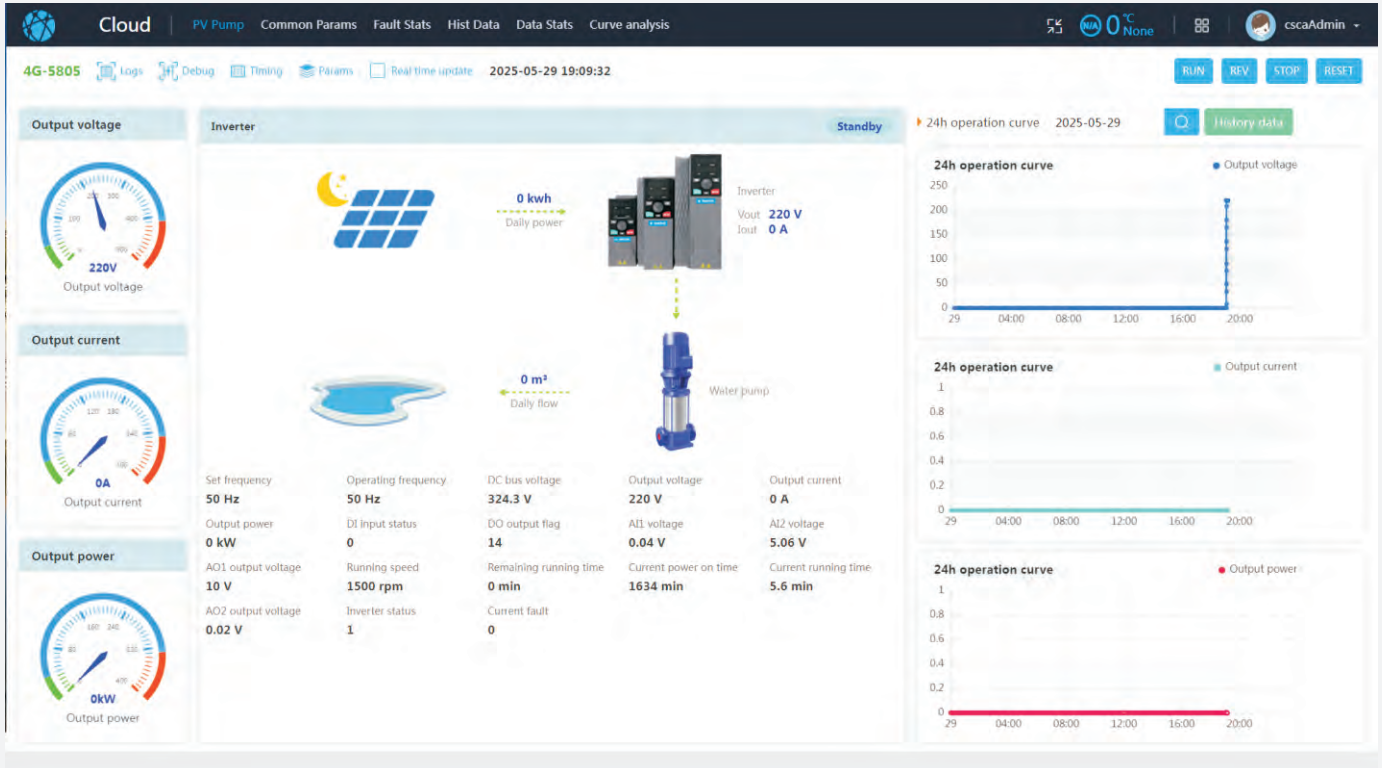

Remote control and monitor from mobile phone side

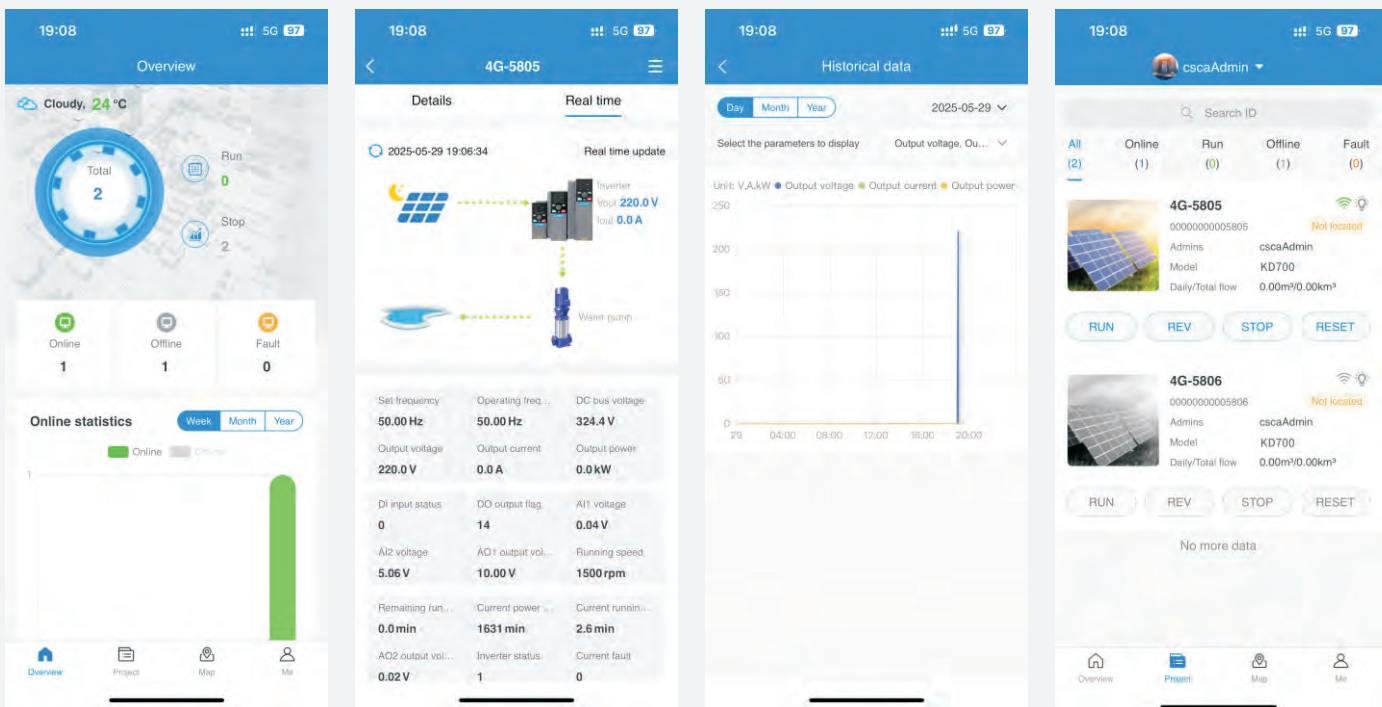

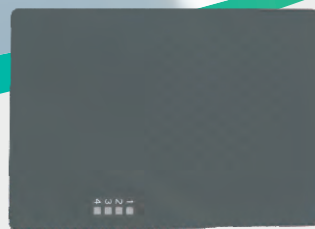
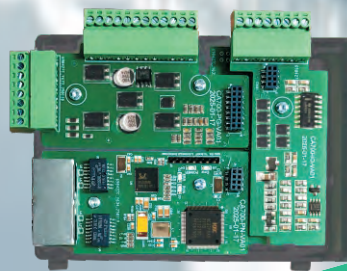

700 Junction Box

KD700 Optional cards

In order to solve the problem that the KD600 series can only connect one expansion card at a time, we have developed this junction box specifically for the 700 series inverter. The 700 series inverter can connect I/O expansion cards, communication expansion cards (EtherCAT, ProfitBUS, ProfitNET) and PG cards (except PLC modules) at one time. Customers can choose external expansion modules by themselves, which can provide more flexible deployment solutions.

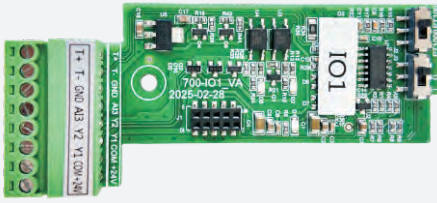

KD700-IO1

I/O expansion card 1

- 5 digital inputs;
- 1 relay output;
- 1 analog AO2 output;
- 1 digital Y2 output, 1 temperature detection (PT100/PT1000/ PTC/KTY).

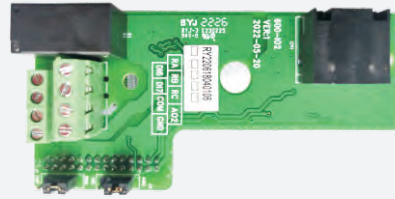

KD700-IO2

I/O expansion card 2

- 2 digital inputs;
- 1 relay output;
- 1 analog AO2 output.

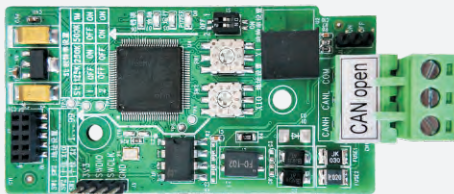

KD700-CANOPEN

CANOPEN communication card

- CANOPEN communication adapter card.

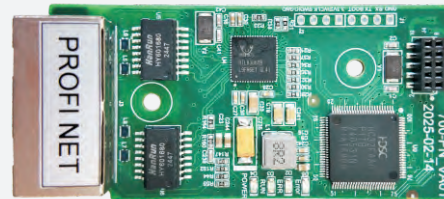

KD700-PROFINET

ProfiNET communication card

- It complies with the internationally accepted Profinet Ethernet standard. The card is installed on the inverter to improve communication efficiency, facilitate the inverter networking function, and make the inverter a slave station of the fieldbus and accept the control of the fieldbus master station.

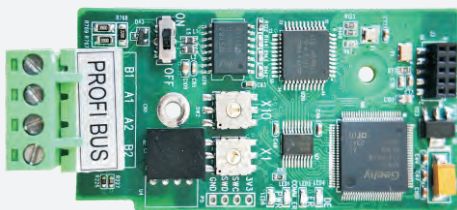

KD700-PROFIBUS

Profibus-DP communication card

- The Profibus-DP fieldbus adapter card complies with the internationally accepted Profibus fieldbus standard, which can improve the communication efficiency of the inverter and realize the networking function, making the inverter a slave station of the fieldbus and accepting the control of the fieldbus master station. This DP expansion card can realize Profibus-DP communication.

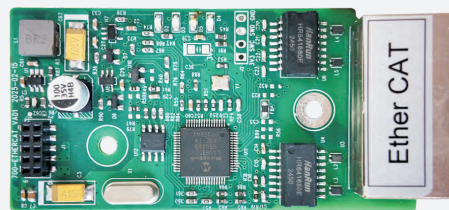

KD700-ETHERCAT

Ether CAT communication card

- Ether CAT fieldbus adapter card can be used for ultra-high-speed I/O networks. This protocol is applicable to the I/O layer.

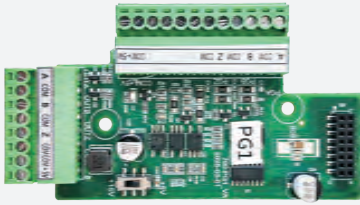

KD700-PG1

ABZ Open integrated electrode PG1 Card

- Open collector PG card (PG card 1 can only be applied to asynchronous motor; compatible with complementary output, encoder card output DC power supply optional +12V or +5V (jumper selection); suitable for asynchronous motor closed loop vector control (VC).

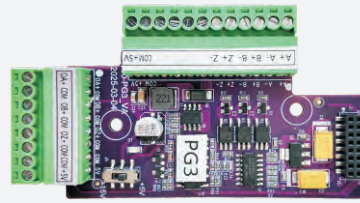

KD700-PG3

ABZ Difference PG3 Card

- ABZ differential signal input PG card: 1:1 differential frequency division output;
- Suitable for asynchronous electric motor closed loop vector control (VC).

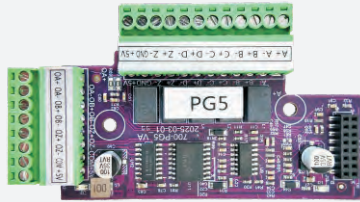

KD700-PG5

Sin/Cos PG5 Card

- Supports sine and cosine signal input; supports differential frequency division output; suitable for synchronous electric motor closed-loop vector control (VC).

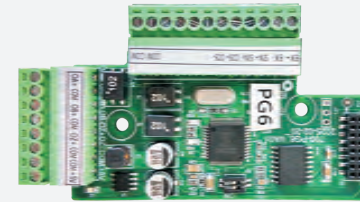

KD700-PG6

Rotary PG6 Card

- Applicable to rotary transformer, DB9 interface, optional shielded encoder cable. Applicable to synchronous traction machine closed loop vector control (VC).

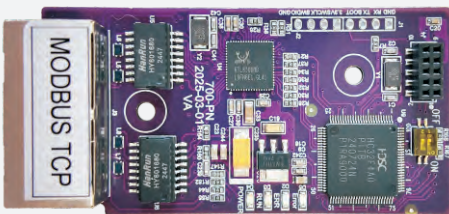

KD700-MODBUS TCP

Modbus TCP Card

- Through the Modbus TCP protocol, the inverter can exchange data with other devices that support Modbus TCP, enabling remote monitoring and control.

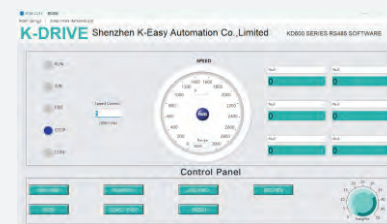

K-DRIVE Monitoring

Host software for PC

- This software communication tool can run on personal computers for drive operation, parameter value setting, waveform monitoring, fault alarm, etc;
- Supports all series.



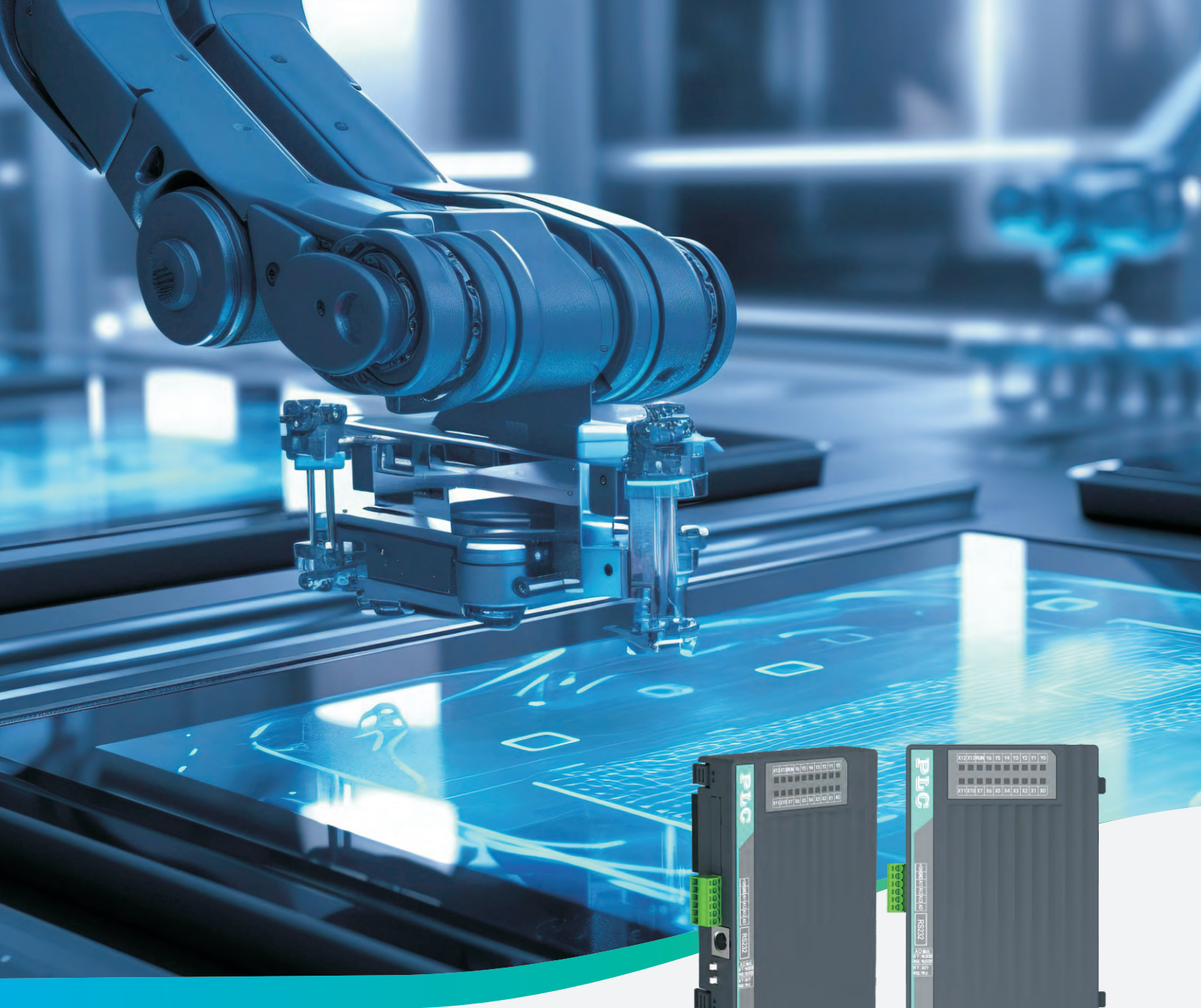

KD700-PLC Expansion Card

KD700-PLC is a newly developed PLC by our company to improve the convenience of customers using PLC in certain occasions. Like expansion cards, it can be directly embedded into the frequency converter, and the software is based on Mitsubishi FX2N.

HARDWARE RESOURCE

Hardware resource	Component type	Parameter
INPUT	X0~X7, X10~X13	12-CH/PNP-NPN/18-30V
Output Point	Y0~Y6	Y0 Y1 transistor type (open drain output), Y2 (A1.B1), Y3 (A2.B2), Y4 (A3.B3), Y5 (A4.B4) are four relay types, and Y6 is occupied by the frequency converter
Analog input	AI1, AI2, AI3	3-CH/supports 0-10V
Analog output	A0	1-CH/Supports 0-10V/0-20mA
Communication output	COM1	PLC program download port Rs232
	COM2	PLC and external communication support RS485 baud rate: 300/600/1200/2400/4800/9600/19200/38400
	COM3	Internal frequency converter occupancy, 300/600/1200/2400/4800/9600/19200/38400

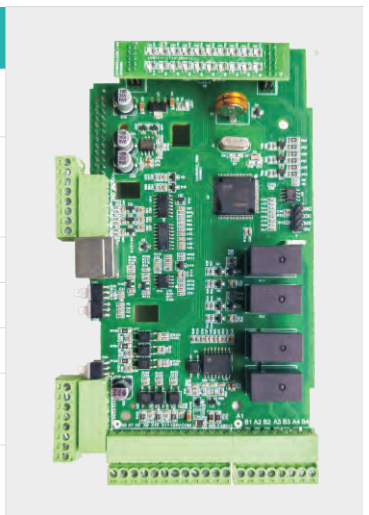

INSTALLATION DIAGRAM

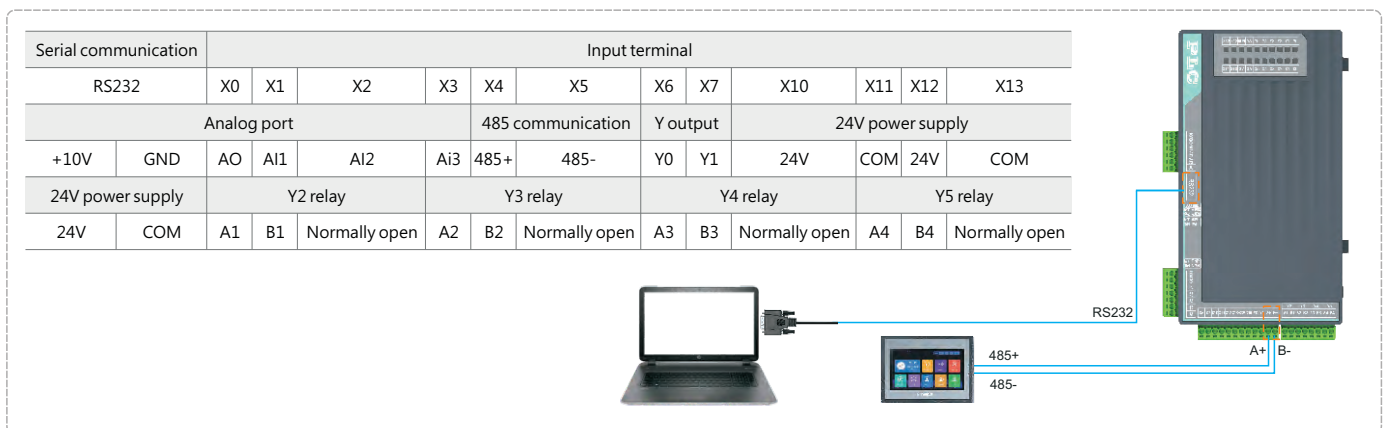

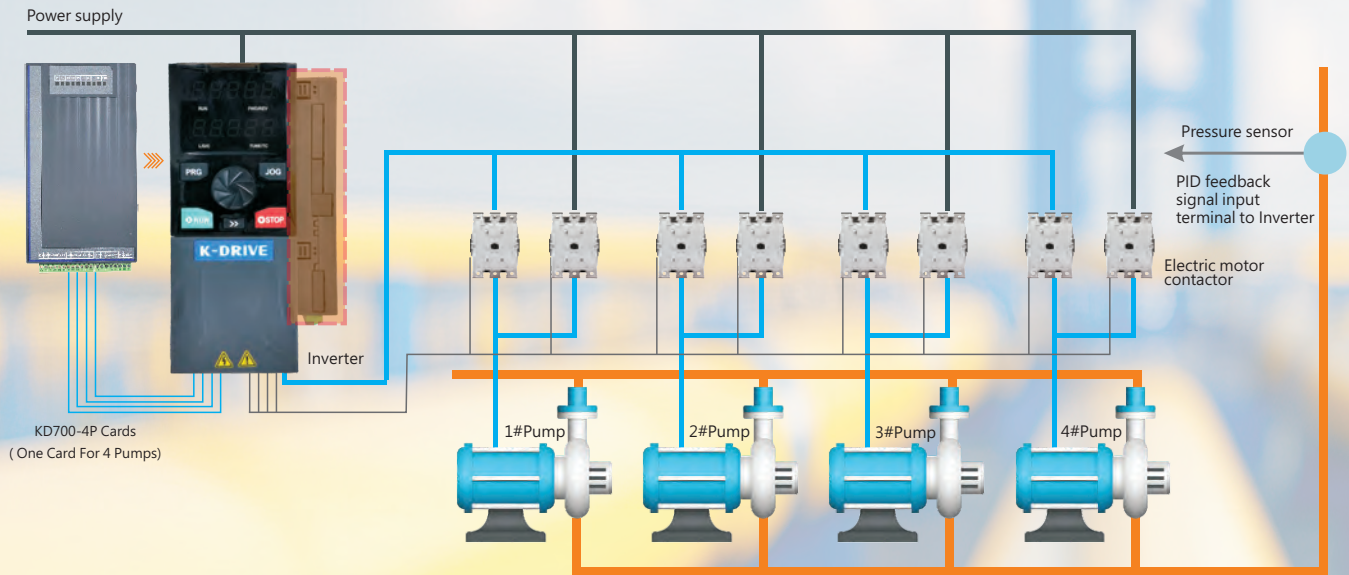

KD700 Series

One to multiple pumps for water supply

ADVANTAGE

- ✧ Replace traditional water pump controllers and achieve 1-4 pumps working together for continuous water supply;
- ✧ Dynamic power matching, equipped with intelligent sleep and wake-up function, with significant energy-saving and efficiency enhancing effects;
- ✧ Adaptive load regulation, supporting rotation operation mechanism, extending the overall service life of the pump unit by about 25% -40%;
- ✧ Multiple linkage protection, supporting multiple protections such as overload, phase loss, overvoltage, overcurrent, high and low voltage alarms, water shortage protection, etc

SENSOR WIRING DIAGRAM

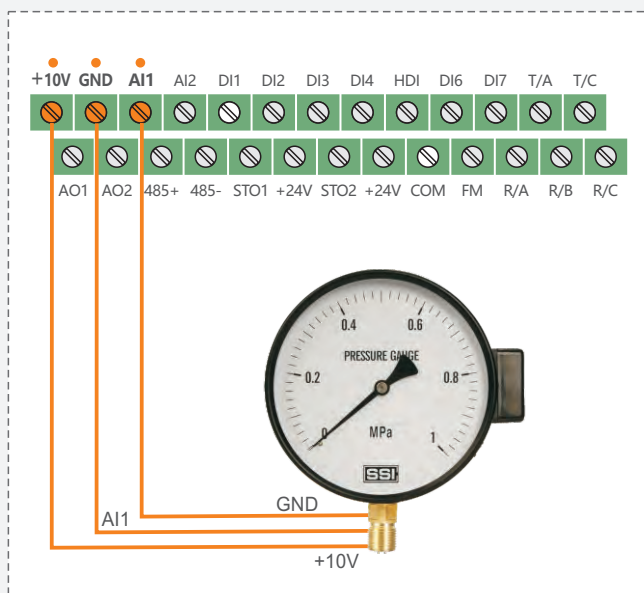

Wiring diagram of remote pressure gauge

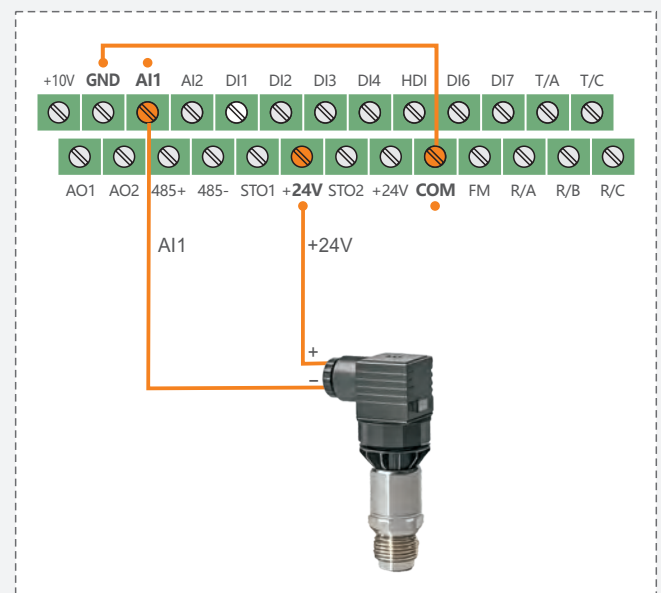

Wiring diagram of 24V pressure sensor

SYSTEM DIAGRAM OF ONE TO MULTIPLE PUMPS

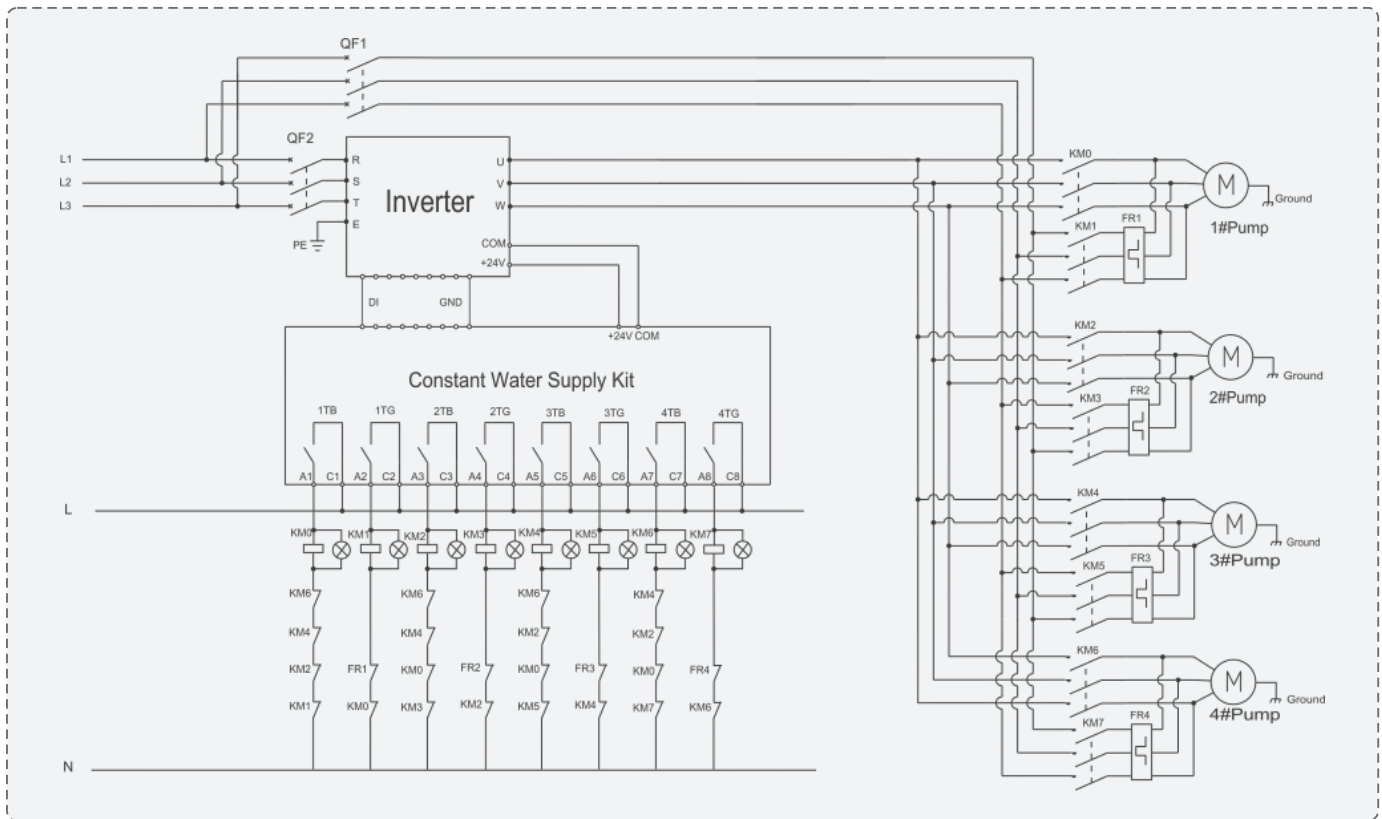

FUNCTIONAL TERMINAL WIRING DIAGRAM AND PARAMETERS

Wiring diagram	Step	Function Code	Set Value	Description
	1	P0-04	1	Terminal control start stop
	2	P0-06	6	The frequency source is PID
	3	P1-13	1	Shutdown mode: Free shutdown
	4	P5-01	11	Di2 function external malfunction
	5	PA-01	Set as needed	PID setpoint
	6	PA-03	0	The PID feedback source is Ai1
	7	PC-16	Set as needed	Selection of pump quantity mode
	8	B6-00	2	Sleep mode selection
	9	B6-01	Set as needed	Sleep frequency
	10	B6-02	Set as needed	Sleep delay
	11	B6-03	Set as needed	Wake up difference

- ✧ Soft start stop combined with PID smooth speed regulation to reduce motor starting impact;
- ✧ Select the number of water pumps according to the demand;
- ✧ Intelligent priority scheduling of water pumps;
- ✧ Fault tolerant switching pump mechanism, pressure fluctuation $< \pm 0.03\text{MPa}$;
- ✧ Excellent energy-saving optimization algorithm, with a comprehensive energy-saving rate of 25% -30% for pump units



Ac Drive



Wind power converter



Servo

SHENZHEN K-EASY AUTOMATION CO.,LIMITED

📍 Shenzhen Office Address:

No. 13, Tangxi Xijing Industrial Zone, Gushu Community,
Xixiang Street, Bao'an District, Shenzhen

Tel: +86-0755-27850411

E-mail: Sales@keasyautomation.com

Http: [//www.keasyautomation.com](http://www.keasyautomation.com)

📍 Hunan Factory Address:

Building 1#, Auto Science and Technology Park, No. 13,
Huanlian Road, Changsha High-tech Development
Zone, Hunan Province

Wechat: +86-19924552818

Whats App: +86-13332991978