

K-DRIVE | K-EASY | 创安睿控

Frequency Inverter | Soft Starter | Servo Drive & Motor | PLC Manufacturer

Pioneer in industry system solutions



ABOUT US

K-DRIVE

13 YEARS⁺ EXPERIENCE VFD MANUFACTURE

Shenzhen K-Easy Automation is a professional manufacturer of inverters and solar pump inverter from Shenzhen, China. Our main products include KD700 book-type high-performance inverters, KD600M mini vector inverters, and KD600 general purpose inverters. All series support solar pump functions. Power range 0.4kw~1000kw; Voltage level: 220V/380V/480V/690V; Communication protocol: Profitbus-DP, ProfitNET, CANopen, EtherCAT, Modbus RS485, Modbus TCP/IP; We have a R&D team of more than 40 engineers, and our products always keep up with market demand, with a variety of tailored products. Strong R&D guarantees our reliable product quality and fast technical support services. We provide a 3-year warranty for all our VFD products.

Shenzhen K-Easy Automation, Çin'in Shenzhen kentinden profesyonel bir invertör ve güneş pompa invertörü üreticisidir. Başlıca ürünlerimiz arasında KD700 kitap tipi yüksek performanslı invertörler, KD600M mini vektör invertörleri ve KD600 genel amaçlı invertörler bulunur. Tüm seriler güneş pompa fonksiyonlarını destekler. Güç aralığı 0,4 kW ~ 1000 kW; Gerilim seviyesi: 220 V / 380 V / 480 V / 690 V; İletişim protokolü: Profitbus-DP, ProfitNET, CANopen, EtherCAT, Modbus RS485, Modbus TCP / IP; 40'tan fazla mühendisin bulunduğu bir Ar-Ge ekibimiz var ve ürünlerimiz her zaman çeşitli özel ürünlerle pazar talebini karşılamaktadır. Güçlü Ar-Ge, güvenilir ürün kalitemizi ve hızlı teknik destek hizmetlerimizi garanti eder. Tüm VFD ürünlerimiz için 3 yıllık garanti sağlıyoruz.

The Only Factory In China Who Can Offer 3 Years Warranty Time



SHENZHEN K-EASY AUTOMATION CO.,LIMITED

Http: //www.keasyautomation.com

K-DRIVE | K-EASY | 创安睿控

Frequency Inverter | Soft Starter | Servo Drive & Motor | PLC Manufacturer

Pioneer in industry system solutions



KD700 Series

BOOK TYPE HIGH-PERFORMANCE VECTOR INVERTER

KD700 is the latest inverter that our company invested 2 million RMB in. Based on KD600, this product can meet all market demands at the cheapest price, supports **TCP/IP (Modbus)** protocol, individually paired **PLC, PROFIBUS, PROFINET, CANOPEN, CAN, ETHERCAT**, etc., and at the same time a parameter can automatically switch to photovoltaic water pump, elevator, synchronous machine, asynchronous machine, etc.

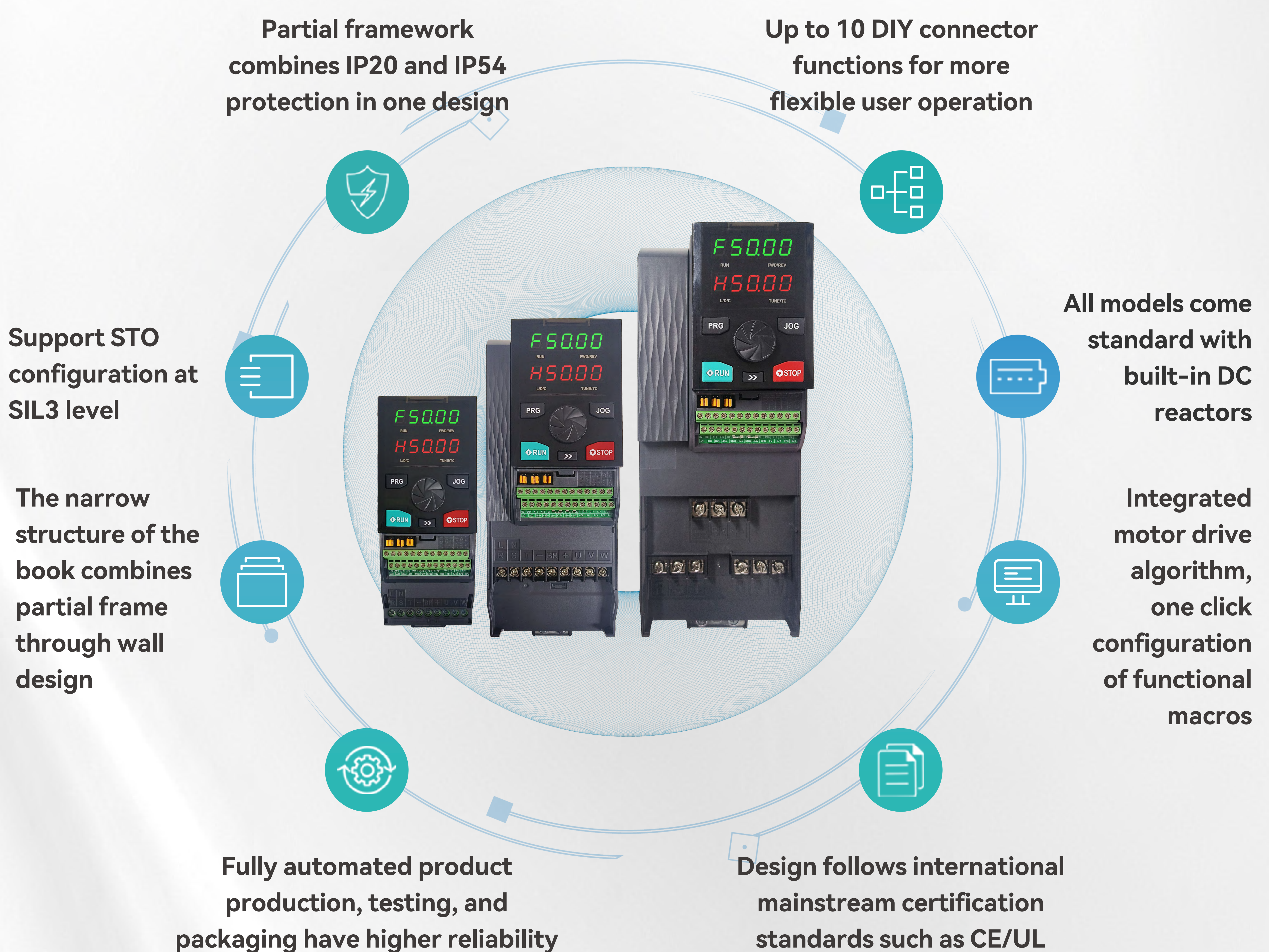

SHENZHEN K-EASY AUTOMATION CO.,LIMITED

Http: //www. keasyautomation.com

K-DRIVE | K-EASY | 创安睿控

Frequency Inverter | Soft Starter | Servo Drive & Motor | PLC Manufacturer

Pioneer in industry system solutions



KD700 Series

BOOK TYPE HIGH-PERFORMANCE VECTOR INVERTER

One Vfd For All software Applicable to **Asynchronous Motor**, **Synchronous Motor**, **Single Motor**, **Elevator Motor** and **Solar Pump**.

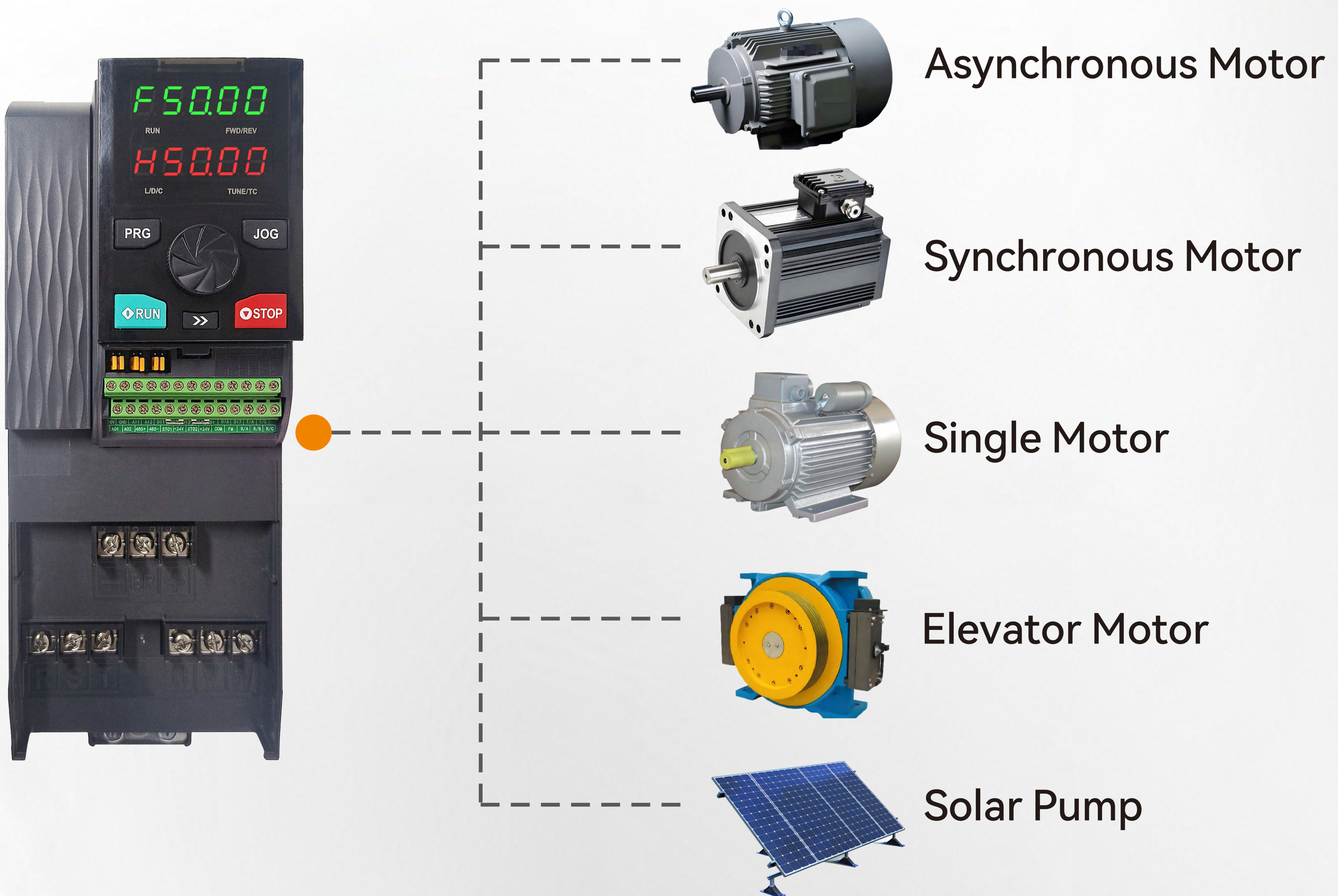

MODULE DESIGN



SHENZHEN K-EASY AUTOMATION CO.,LIMITED

Http: //www. keasyautomation.com

K-DRIVE | K-EASY | 创安睿控

Frequency Inverter | Soft Starter | Servo Drive & Motor | PLC Manufacturer

Pioneer in industry system solutions



External Expansion Module

KD700 Series

BOOK TYPE HIGH-PERFORMANCE VECTOR INVERTER

In order to solve the problem that the KD600 series can only connect one expansion card at a time, we have developed this junction box specifically for the 700 series inverter. The 700 series inverter can connect I/O expansion cards, communication expansion cards (EtherCAT, ProfitBUS, ProfitNET) and PG cards (except PLC modules) at one time. Customers can choose external expansion modules by themselves, which can provide more flexible deployment solutions.

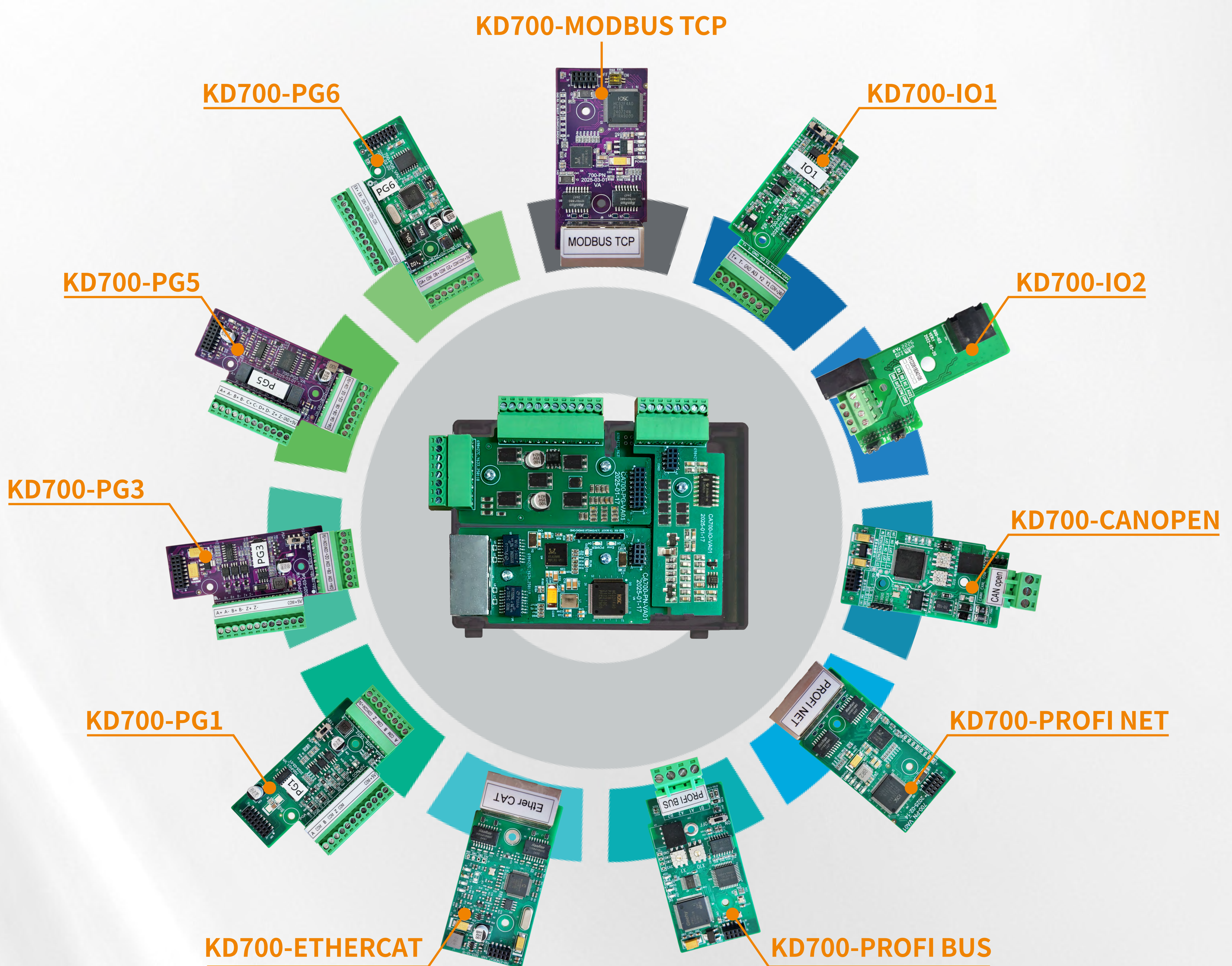

SHENZHEN K-EASY AUTOMATION CO.,LIMITED

Http: //www. keasyautomation.com

K-DRIVE | K-EASY | 创安睿控

Frequency Inverter | Soft Starter | Servo Drive & Motor | PLC Manufacturer

Pioneer in industry system solutions

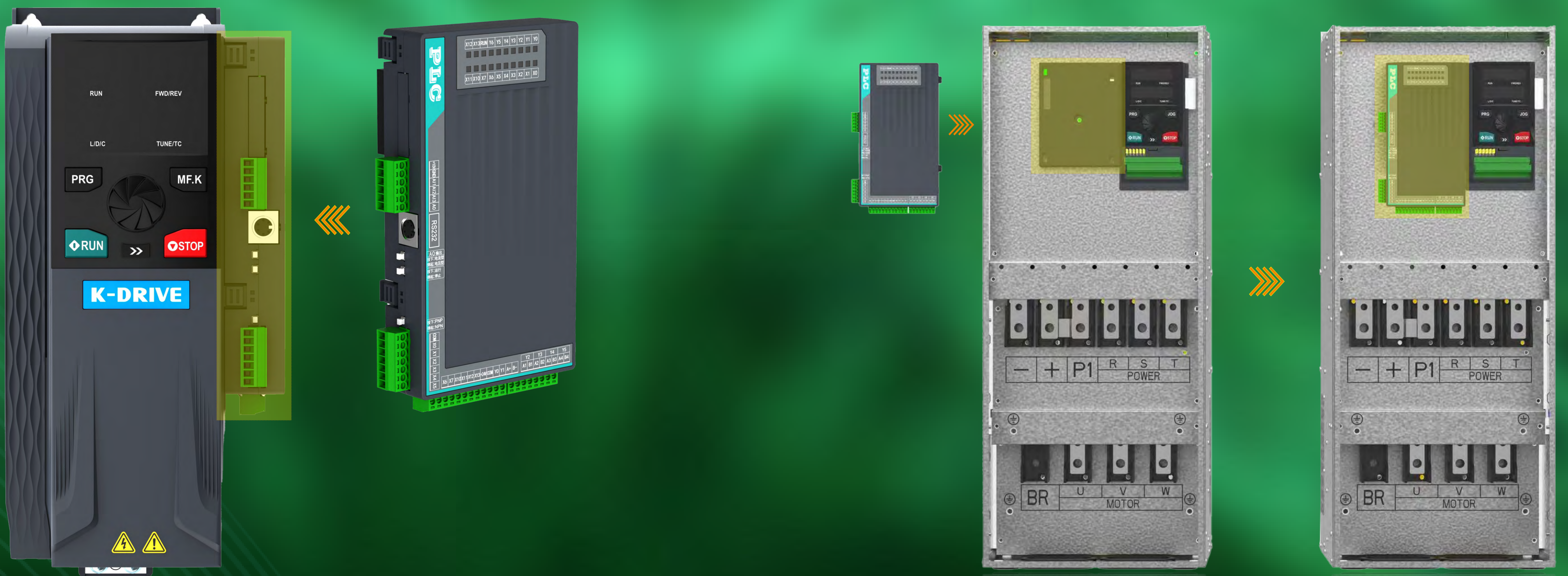

PLC Expansion Card

KD700 Series

BOOK TYPE HIGH-PERFORMANCE VECTOR INVERTER

KD700-PLC is a newly developed PLC by our company to improve the convenience of customers using PLC in certain occasions. Like expansion cards, it can be directly embedded into the frequency converter, and the software is based on Mitsubishi FX2N.

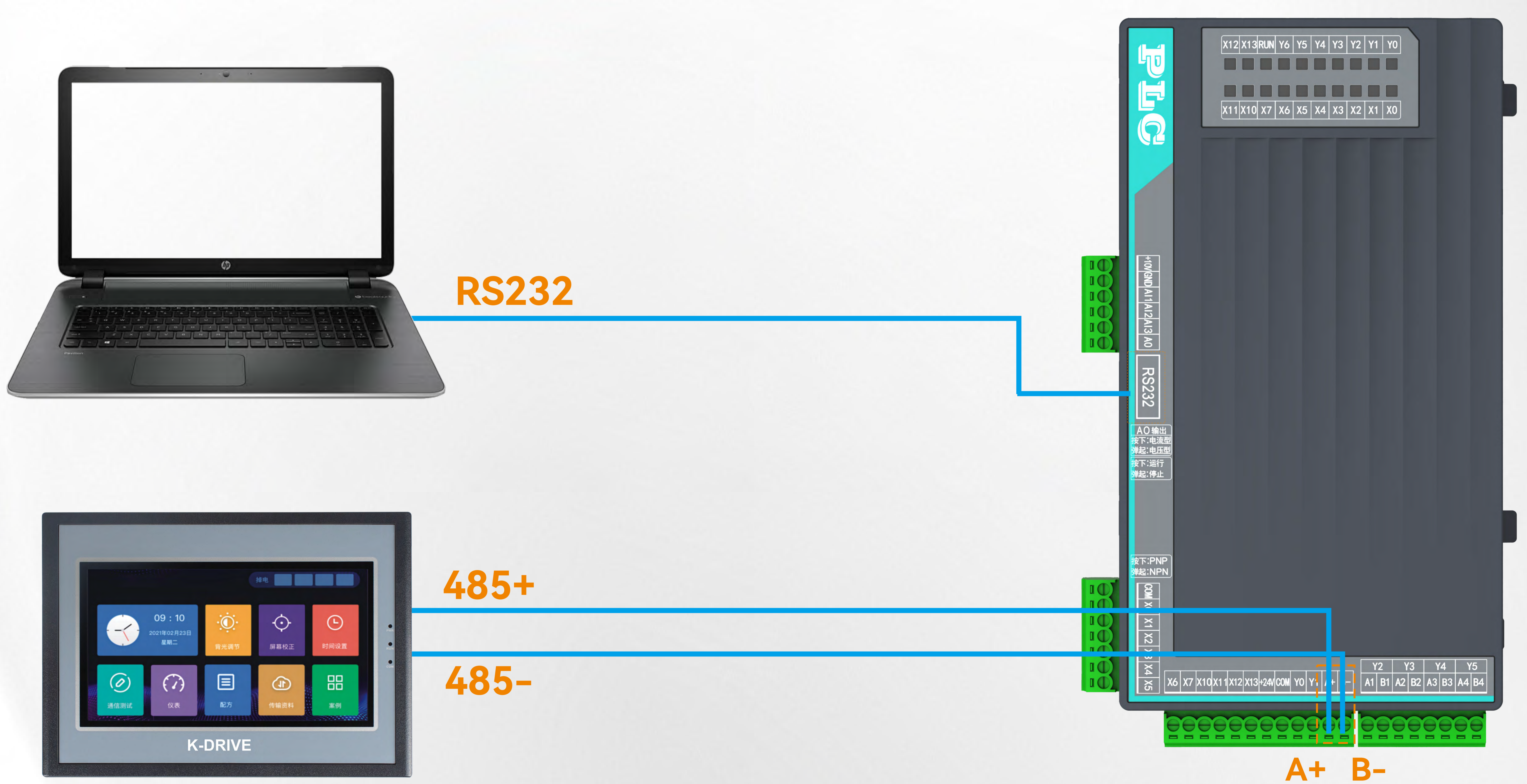

Serial communication		Input terminal											
Rs232		X0	X1	X2	X3	X4	X5	X6	X7	X10	X11	X12	X13
Analog port				485 communication				Y output		24V power supply			
+10V	GND	AO	AI1	AI2	AI3	485+	485-	Y0	Y1	24V	COM	24V	COM
24V power supply		Y2 relay			Y3 relay			Y4 relay			Y5 relay		
24V	COM	A1	B1	Normally open	A2	B2	Normally open	A3	B3	Normally open	A4	B4	Normally open

SHENZHEN K-EASY AUTOMATION CO.,LIMITED

Http: //www. keasyautomation.com

K-DRIVE | K-EASY | 创安睿控

Frequency Inverter | Soft Starter | Servo Drive & Motor | PLC Manufacturer

Pioneer in industry system solutions



KD600M Series

HIGH PERFORMANCE UNIVERSAL VECTOR INVERTER

KD600M is our new design with the most compact size but good vector Control Mode, Can be easily tuned to simple speed control for **80% Motors**, really cheapest price, and good function.. with **24 months** warranty offered, it can almost match all customers' requests.

Product Characteristics

- Compact design, saving installation space;
- Motor output short-circuit protection;
- Support LCD keypad, parameter copy function;
- Programmable DI/DO/AI/AO;
- MODBUS RS485 communication;
- Integrated PID function support most of water supply applications;
- Integrated multi-speed function support maximum 16 speeds;
- Support fire override mode.

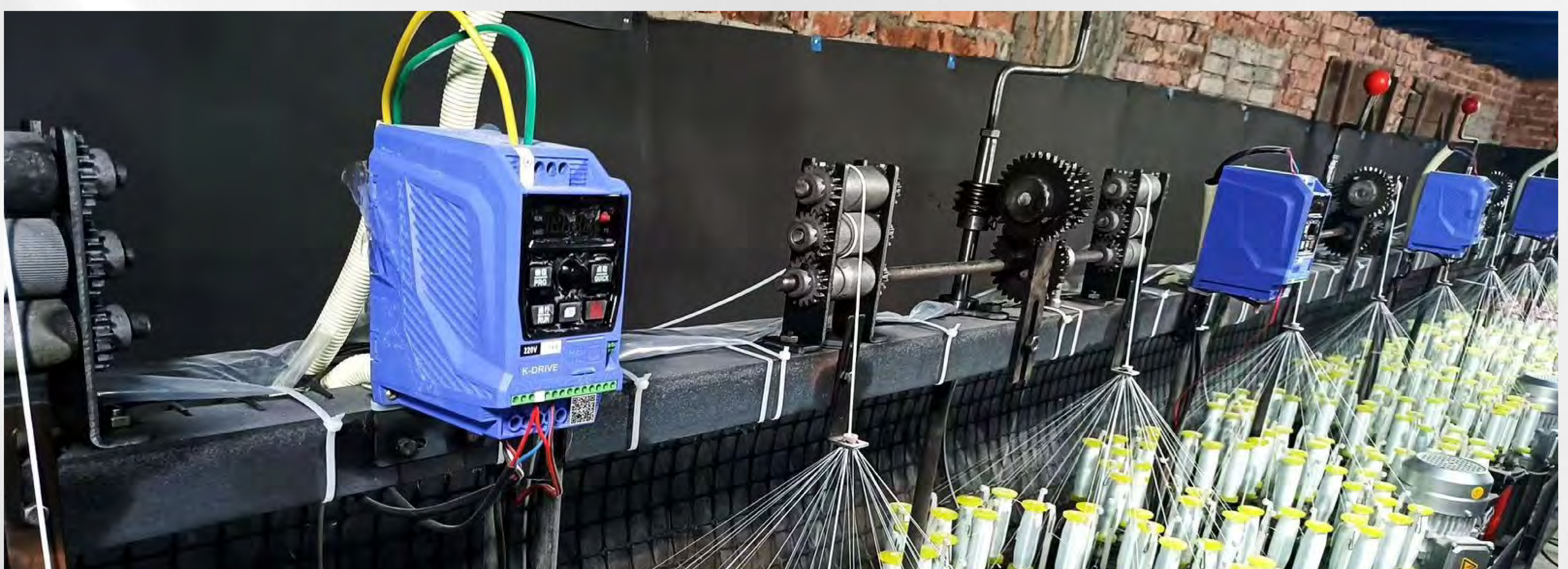

SHENZHEN K-EASY AUTOMATION CO.,LIMITED

Http: [//www.keasyautomation.com](http://www.keasyautomation.com)

K-DRIVE | K-EASY | 创安睿控

Frequency Inverter | Soft Starter | Servo Drive & Motor | PLC Manufacturer

Pioneer in industry system solutions



KD700E Series

ELEVATOR SPECIFIC FREQUENCY INVERTER

KD700E are specific for passenger and freight elevators installed in residential buildings, shopping malls, and office buildings. The drives can be programmed to have a commendable leveling even they adopt open-loop control, reducing the cost of additional devices. Flexible S-curve program greatly improves comfortability for the elevator users. All elevator parameters gathered in one chapter in the user manual, and well furnished parameter default values make the commissioning easy and fast.

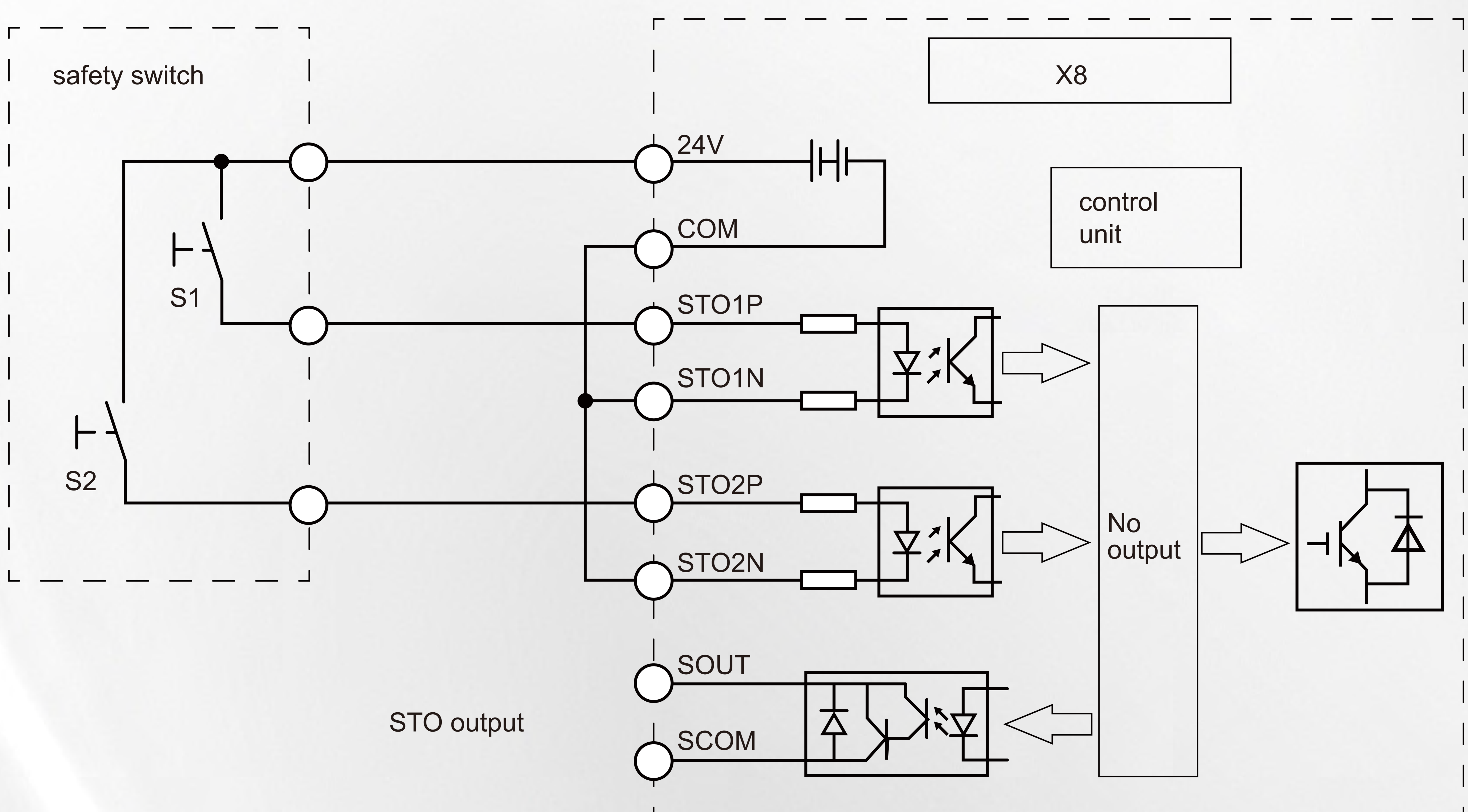

SHENZHEN K-EASY AUTOMATION CO., LIMITED

Http: //www. keasyautomation.com

K-DRIVE | K-EASY | 创安睿控

Frequency Inverter | Soft Starter | Servo Drive & Motor | PLC Manufacturer

Pioneer in industry system solutions



SP600M/SP700 SP600-IP65 Series

DEDICATED AC DRIVE FOR SOLAR PUMP

SP600M/SP700/SP600-IP65 series solar pump dedicated drives are applied to both **asynchronous motor** and **PMSM**. The mains input can be solar panel DC, AC single phase, or AC three phase. Users are free to choose a single-phase motor or three-phase motor according to the wish.

Thanks to the inbuilt **MPPT** (Maximal Power Point Tracking) function, SP600M/SP700/SP600-IP65 series drives have a fast response to the sunlight change and reach maximal power point promptly, making the system working at its highest efficiency always.

Photovoltaic system connection diagram

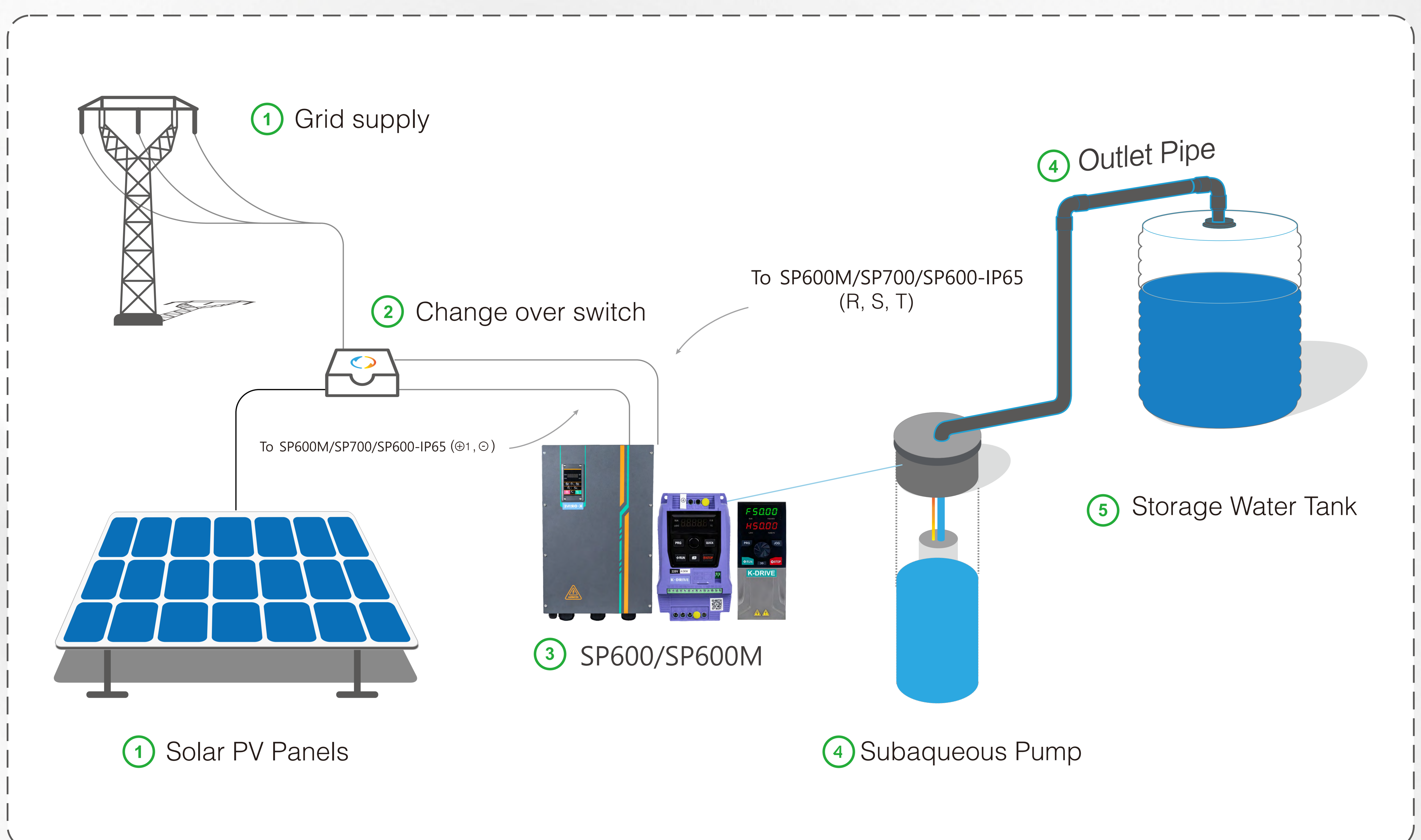

SHENZHEN K-EASY AUTOMATION CO., LIMITED

Http: //www. keasyautomation.com

K-DRIVE | K-EASY | 创安睿控

Frequency Inverter | Soft Starter | Servo Drive & Motor | PLC Manufacturer

Pioneer in industry system solutions



CBR600 DBU Braking Unit CL100 Feedback Unit

CBR600 series DBU braking unit support heavy duty and master slave parallel installation.

The CL100 feedback unit adopts advanced control algorithms, which have the characteristics of high efficiency, high power factor, and low harmonic interference. Applied in situations where electric energy regeneration and high requirements for harmonic and energy conservation and emission reduction are required during variable frequency speed regulation. The feedback unit ensures effective braking of variable frequency speed regulation while returning more than 97% of renewable energy to the power grid, achieving the goal of energy conservation and emission reduction.



Compared to traditional energy consumption braking

Comprehensive energy-saving rate

Up to **20%~60%**



SHENZHEN K-EASY AUTOMATION CO.,LIMITED

Http: [//www.keasyautomation.com](http://www.keasyautomation.com)

K-DRIVE | K-EASY | 创安睿控

Frequency Inverter | Soft Starter | Servo Drive & Motor | PLC Manufacturer

Pioneer in industry system solutions



CL200 Series

FOUR-QUADRANT INVERTER

CL200 series four-quadrant inverter adopts IGBT as rectification bridge, and uses DSP with high speed and high computing power to generate PWM control pulse. On the one hand, the input power factor can be adjusted to eliminate harmonic pollution to the power grid. On the other hand, the energy generated by the motor can be returned to the power grid to achieve a thorough energy-saving effect. Products support three-phase asynchronous motor and permanent magnet synchronous motor control, strong performance, stable and reliable, can be used in pumping units, cranes, elevators, lifts and other industries.

